

TOOLS & SHOP SUPPLIES

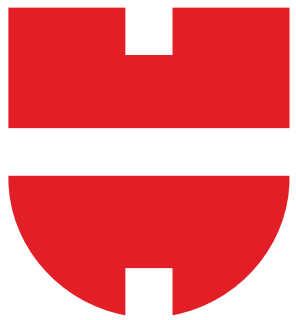



WÜRTH

08**Tools & Shop Supplies**

A/C Supplies	08.0640 - 08.0650	Nipple Interchange Chart	08.0105 - 08.0125
Adhesive Back Fastener	08.0570	Pin Punch Set	08.0635
Air Evac II	08.0265	Pistol Vac	08.0260
Air Hose & Regulators	08.0250 - 08.0255	Plastic Lined Lug Sockets	08.0635
Air Hose Accessories	08.0175 - 08.0180, 08.0240	Pliers & Shears	08.0385
Air Sanders	08.0095	Protective Covers	08.0585 - 08.0600
Air Tools	08.0075 - 08.0080	Racks	08.0660 - 08.0670
Airline Filters & Regulators	08.0245	Ratchet Bit Set	08.0020
Arbors, Pilot Drills	08.0300	Rivet Tools	08.0040 - 08.0050
Assortment Boxes	08.0675	Safety Eyewear	08.0710 - 08.0715
Bit Holders & Adapters	08.0320 - 08.0335	Saws & Cutters	08.0340 - 08.0345
Blow Guns	08.0260	Shop Supplies	08.0615 - 08.0625
Brass	08.0185 - 08.0235	Socket Sets	08.0025 - 08.0035
Brushes	08.0360 - 08.0365	Spill Control	08.0605 - 08.0610
Caulking Guns	08.0445 - 08.0460	Spray Guns	08.0465 - 08.0470
Couplers	08.0130 - 08.0170	Storage	08.0655, 08.0680 - 08.0685
DBS 3600	08.0100	Stud Driver & Remover	08.0360
Dent Lifters	08.0065 - 08.0070	Stud Extractor	08.0630
Dispensers	08.0405 - 08.0435	Tape	08.0535 - 08.0565
Drill Bits	08.0290 - 08.0295	Twist Drills	08.0270 - 08.0285, 08.0310 - 08.0315
Ear Protection	08.0705	Valve Adjusting Tools	08.0630
Electrical Hand Tools	08.0390 - 08.0400	Vario Point Cutters	08.0085 - 08.0090
Files	08.0350 - 08.0355	Welding Supplies	08.0480 - 08.0495
Gloves	08.0720 - 08.0745	Wire & Grinding Wheels	08.0570 - 08.0575
Grease Guns	08.0435 - 08.0440	Work Lights	08.0520 - 08.0530
Hand Tools	08.0055 - 08.0060	Wrenches	08.0005 - 08.0015
Heating Tools	08.0500 - 08.0515		
Holesaws	08.0305		
Knives & Blades	08.0370 - 08.0375		
Masks	08.0690 - 08.0700		
Micro Grip	08.0475		

WÜRTH COMBINATION WRENCHES WITH POWERDRIV®



For a sure grip and higher transmission of force.

- Extremely strong, high quality chrome vanadium steel
- Withstands the highest loads
- Exceptionally long service life
- Achieves the highest torque values
- Low deformation under extreme loads

POWERDRIV®

The POWERDRIV® system was developed to meet the particularly high demands in the aviation industry in order to provide the highest level of fit tolerances. The POWERDRIV® system enables a higher transmission of forces at the ring and reduces wear on the bolt heads.

Perfect Workmanship

- Nickel pre-treatment provides optimal adhesion of chrome even in extremely heavy duty.
- Round finish without any sharp edges and corners.
- Matte chrome-plating provides sure grip, even with oily hands.
- Exact fit due to high-gloss polish.
- FEM calculation concentrates the material where the loads offer.
- Tightest tolerances of the jaw openings guarantee more reliability and safety in intensive use.

The Principle

The POWERDRIV® does not grip the bolt heads as usual at the corners but on the flanks.

- This enlarges the driving flat, thus permitting a surer grip of the ring and a higher transmission of force.
- The service life of bolts is increased noticeably because rounding off of the bolt heads is avoided.
- Even old and rusty bolts can be undone with POWERDRIV® without any rounding off.

Exceeds DIN Standards by far

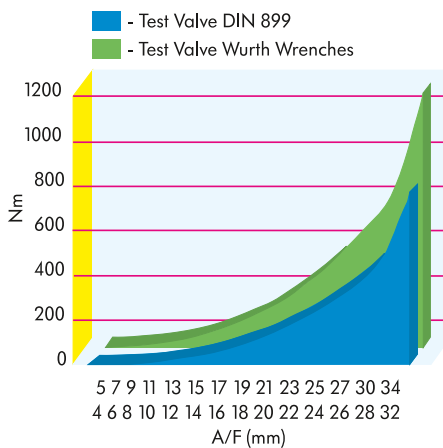

Torque Values in excess of DIN:

Highest torque values for the most extreme conditions.



Without POWERDRIV® - Line pressure

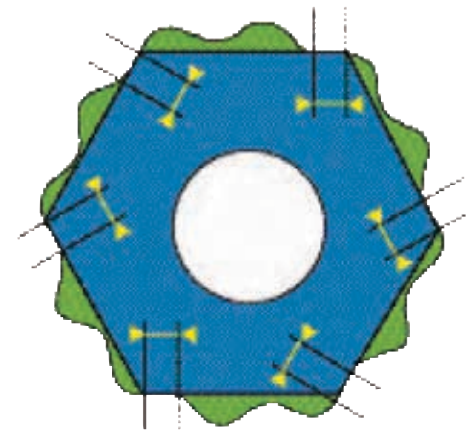

With POWERDRIV® - Line pressure

WURTH METRIC THIN LINE DOUBLE OPEN END WRENCH SET



- Standard: DIN 3110 / ISO 1085
- Material: Chrome vanadium steel
- Surface finish: Chrome-plated polished heads
- Jaw position 15° , strong heads for heavy duty use



Set	in mm	Art #
12	6x7, 8x9, 10x11, 12x13, 14x15, 16x17, 18x19, 20x22, 21x23, 24x27, 25x28, 30x32	071330443

WURTH METRIC & US COMBINATION WRENCH SETS



- Ring end POWERDRIV® double hex
- Standard: DIN 3113A / ISO 3318/7738
- Material: Chrome vanadium steel
- Surface finish: Chrome-plated polished heads
- Jaw position 15° , strong heads for heavy duty use
- Double hex ring and jaw position of 15° for an optimal grip ratio, resulting in minimal rotating angle
- The 15° angle of the ring wrench provides more free space for the fingers or to work around obstacles

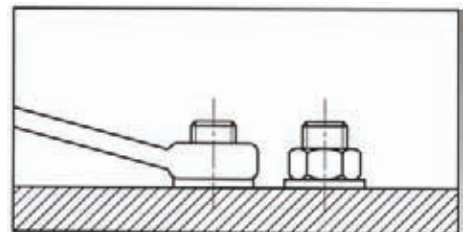
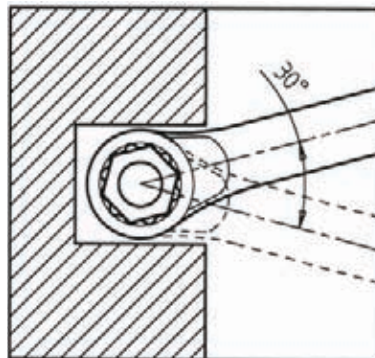
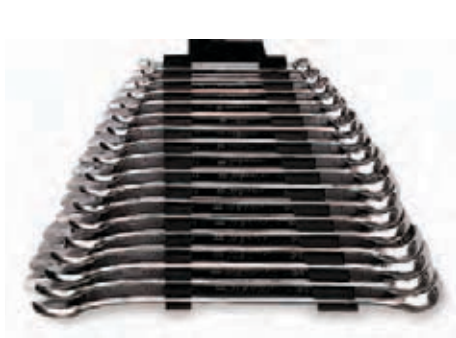

Set	in mm	Art #
11	8, 9, 10, 11, 12, 13, 14, 15, 17, 19, 22	071330140

WURTH METRIC DOUBLE ENDED OFFSET BOX END WRENCH SET



- POWERDRIV® double hex
- Standard: DIN 838 / ISO 3318
- Material: Chrome vanadium steel
- Surface finish: Chrome-plated polished heads
- Ring end offset by 18°
- The slim design is characterized by minimized external dimensions, pronounced rounded contours and smooth edges



- Deep-set bolt connections can be loosened optimally due to the deep-offset and fine ring heads

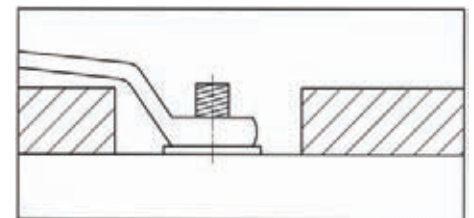
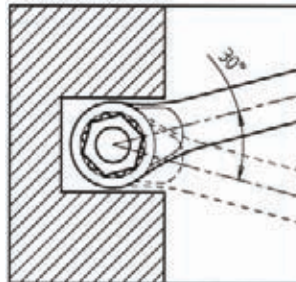

Set	in mm	Art #
8	6x7, 8x9, 10x11, 12x13, 14x15, 16x17, 18x19, 20x22	071330540

FLEX RATCHET RING WRENCH

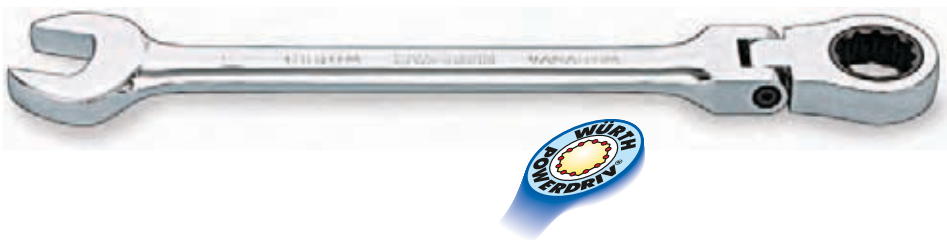

- Power take-off: ring end POWERDRIV® bihexagonal, fine pitch, 72 teeth
- Standard: max. torque according to DIN 899
- Material: Chrome-Vanadium steel
- Surface finish: bright polished, chrome-plated
- Geometry: open end offset 15°, ring end 180° joint, sturdy heads for heavy duty use
- Application: loosen screws with open end, unscrew with ratchet mechanism of ring end
- This is a special tool that may not be subjected to loads in excess of maximum torque values. For that reason, the tool is of limited suitability for loosening of tight screws

- The 180° articulated joint of the ring wrench allows easy and flexible access to work, even in close tolerance areas

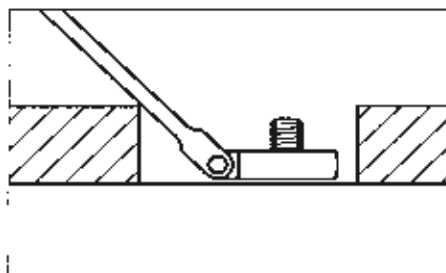
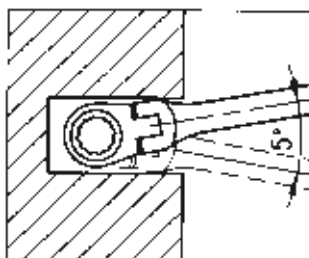

Sold Separately:

Art. #	in mm	Art. #	in mm	Art. #	in mm
071425308	8	071425312	12	071425316	16
071425309	9	071425313	13	071425317	17
071425310	10	071425314	14	071425318	18
071425311	11	071425315	15	071425319	19

Set	in mm	Art #
6	8, 10, 12, 13, 17, 19	071425350

RATCHET BIT SET 10 MM DIAMETER



Bit set especially for automobiles and commercial vehicles, 38 pieces.

- Ratchet for 10 mm bits
- Additional adapter allows use of a 1/2" ratchet
- Supplied in a metal box with high quality interior foam compartment with clamping effect

Description	Art #
Ratchet Bit Set	096512370

Destination	Drive	Length	Art. #		
Ratchet for 10mm bits		175mm	071412100		
Adapter for 1/2" ratchet		37mm	07151303		
TX 20 with pin		30mm	061478820		
TX 25 with pin			061478825		
TX 27 with pin			061478827		
TX 30 with pin			061478830		
TX 40 with pin			061478840		
TX 45 with pin			061478845		
TX 50 with pin			061478850		
TX 55 with pin			061478855		
TX 20				75mm	0614788120
TX 25					0614788125
TX 27	0614788127				
TX 30	0614788130				
TX 40	0614788140				
TX 45	0614788145				
TX 50	0614788150				
TX 55	0614788155				

Destination	Drive	Length	Art. #		
TX 40		120 mm	0614788240		
TX 45			0614788245		
TX 50			0614788250		
Hexagon socket M5		30 mm	0614788305		
Hexagon socket M6			0614788306		
Hexagon socket M7			0614788307		
Hexagon socket M8			0614788308		
Hexagon socket M10			0614788310		
Hexagon socket M12			0614788312		
Triple Square M5		30 mm	0614788405		
Triple Square M6			0614788406		
Triple Square M8			0614788408		
Triple Square M10			0614788410		
Triple Square M12		75 mm	0614788412		
Triple Square M6			0614788506		
Triple Square M8			0614788508		
Triple Square M10			0614788510		
Triple Square M12		75 mm	0614788512		
PH 2				30 mm	0614788902
PH 3					0614788903

Ratchet for 10 mm bits

- Head: 72 teeth, swivel angle 5°, round, compact head
- Shaft: chrome-plated, high-grip 2-component handle

Description	Art #
Ratchet for 10 mm bits	071412100



- ① Ratchet with short 10 mm bit
- ② 1/2" ratchet with adapter

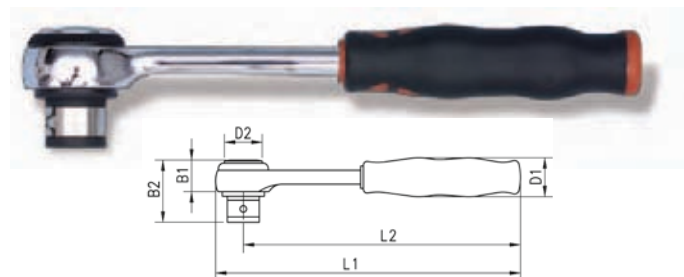

L1	L2	B1	B2	D1	D2	Art #
175	160	19	33	26	20	071412100
Repair Set						071511311

1/4" MULTI-USE SOCKET SET



- Take-off: by-hexagon, multi-use profile
- Geometry: short
- Supplied in a metal box with high-quality foam insert compartment
- Newly developed multi-purpose profile fitting the 5 most common screw heads. Therefore, one set is sufficient for all requirements
- Hexagon metric, square metric, bi-hexagon metric, hexagon inch and external Torx
- High-quality multi-use socket bits guarantee a long service life
- Chrome plated and polished

Description	Art #
1/4" Multi-Use Socket Set, 32 pcs.	096511032



Multi-Use Profile	Metric Hex.	US Hex.	Ext. Torx	Square	Art. #
mm	mm	inch	TX	mm	
4	size 4	5/32"	E5	—	071311304
5	size 5	—	—	size 4	071311305
5.5	size 5.5	7/32"	—	size 4.5	0713113055
6	size 6	—	E8	size 5	071311306
7	size 7	9/32"	—	—	071311307
8	size 8	5/16"	E10	—	071311308
9	size 9	11/32"	—	—	071311309
10	size 10	3/8"	E12	size 8	071311310
11	size 11	7/16"	E14	size 9	071311311
12	size 12	15/32"	E16	size 10	071311312
13	size 13	1/2"	—	—	071311313
14	size 14	9/16"	E18	—	071311314

Description	Drive	Length	Art. #
Reversing ratchet		138 mm	071411151
Extension		100 mm	0713118104
Extension		150 mm	0713118106
Universal Joint		33 mm	0713118301
Screwdriver handle		216 mm	0613430311
Adapter with quick change chuck		30 mm	07151101
12 multi-use sockets, one each sizes 4-14		22 mm	071311304 Thru 071311314
Bit PH 2		25 mm	0614176461
Bit hex, socket size 3			061417693
Bit hex, socket size 4			061417694
Bit hex, socket size 6			061417696
TX 10		25 mm	06143110
TX 15			06143115
TX 20			06143120
TX 25			06143125
TX 30			06143130
TX 40			06143140

3/8" MULTI-SOCKET SET



- Bit: 12-sided, multi-profile
- Geometry: short
- Supplied in a metal box with high-quality foam insert compartment
- Newly developed multi-purpose profile fitting the 5 most common screw heads. Therefore, one set is sufficient for all requirements
- Hexagon metric, square metric, bi-hexagon metric, hexagon inch and external Torx
- High-quality multi-use socket bits guarantee a long service life
- Chrome plated and polished

Description	Art #
3/8" Multi-Socket Set, 22 pcs.	096512022



Hexagonal metric



Bi-hexagonal metric



Hexagon inch



Square metric



External Torx

Multi-Use Profile	6-sd./12-sd.	US Hex.	Ext. Torx	Square	
mm	mm	inch	TX	mm	Art. #
6	6	—	E8	5	071312306
6.3	6.3	1/4"	—	—	0713123063
7	7	9/32"	—	—	071312307
8	8	5/16"	E10	—	071312308
9	9	11/32"	—	—	071312309
10	10	3/8"	E12	8	071312310
11	11	7/16"	E14	9	071312311
12	12	15/32"	E16	10	071312312
13	13	1/2"	—	—	071312313
14	14	9/16"	E18	—	071312314
15	15	19/32"	—	12	071312315
16	16	5/8"	E20	13	071312316
17	17	—	—	14	071312317
18	18	—	E22	—	071312318
19	19	3/4"	E24	—	071312319
20	20	25/32"	—	16	071312320
21	21	13/16"	E26	17	071312321
22	22	7/8"	E28	18	071312322

Description	Drive	Length	Art. #
Ratchet		175 mm	071412151
Extension		125 mm	0713128105
Extension		250 mm	0713128110
Universal Joint		55 mm	0713128301
18 Multi-Use Sockets, 1 each - Sizes 6-22 mm		25.5 - 31 mm	071312306 - 071312322

1/2" MULTI-SOCKET SET



- Tip: 12-sided, multi-profile
- Geometry: short
- Supplied in a metal box with high-quality foam insert compartment
- Newly developed multi-purpose profile fitting the 5 most common screw heads. Therefore, one set is sufficient for all requirements
- Hexagon metric, square metric, bi-hexagon metric, hexagon inch and external Torx
- High-quality multi-use socket bits guarantee a long service life
- Chrome plated and polished

Description	Art #
1/2" Multi-Socket Set, 23 pcs.	096513023



Multi-Use Profile	6-sd./12-sd.	US Hex.	Ext. Torx	Square	
mm	mm	inch	TX	mm	Art. #
10	size 10	3/8"	E12	size 8	071213410
11	size 11	7/16"	E14	size 9	071213411
12	size 12	15/32"	E16	size 10	071213412
13	size 13	1/2"	—	—	071213413
14	size 14	9/16"	E18	—	071213414
15	size 15	19/32"	—	size 12	071213415
16	size 16	5/8"	E20	size 13	071213416
17	size 17	—	—	size 14	071213417
18	size 18	—	E22	—	071213418
19	size 19	3/4"	E24	—	071213419
20	size 20	25/32"	—	size 16	071213420
21	size 21	13/16"	E26	size 17	071213421
22	size 22	7/8"	E28	size 18	071213422
24	size 24	15/16"	E30	size 19	071213424
26	size 26	—	E32	size 21	071213426
27	size 27	11/16"	E34	size 22	071213427
28	size 28	1-1/8"	E36	size 23	071213428
30	size 30	1-3/16"	E38	size 24	071213430
32	size 32	1-1/4"	E40	size 26	071213432

Description	Drive	Length	Art. #
Reversing Ratchet		250 mm	0712012
Extension		125 mm	0712138105
Extension		250 mm	0712138110
Universal Joint		70 mm	0712138301
19 Multi-Use Sockets, 1 each - Sizes M10-M32		36 mm - 44 mm	071213410 - 071213432

RIVET GUN FOR PLASTIC RIVETS



- Sets most rivets in one stroke without regripping
- Won't break stem before rivet is set
- Won't damage painted, plated or easily marred surfaces

Description	Art #
Rivet Gun for Plastic Rivets	19490001

LONG ARM RIVET NUT GUN WITH METRIC MANDRELS

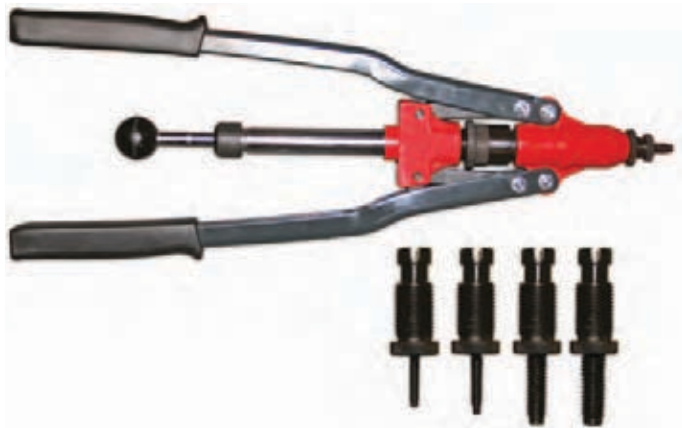

Includes	Art #
4mm, 5mm, 6mm, 8mm and 10mm mandrels	1917400

Sold Separately	Art #
4mm mandrel	091740201
5mm mandrel	091740202
6mm mandrel	091704203
8mm mandrel	091704204
10mm mandrel	091704205
4mm nose piece	091704206
5mm nose piece	091704207
6mm nose piece	091704208
8mm nose piece	091704209
10mm nose piece	091704210

Total installation time 11 seconds!



LONG ARM RIVET NUT GUN WITH STANDARD MANDRELS

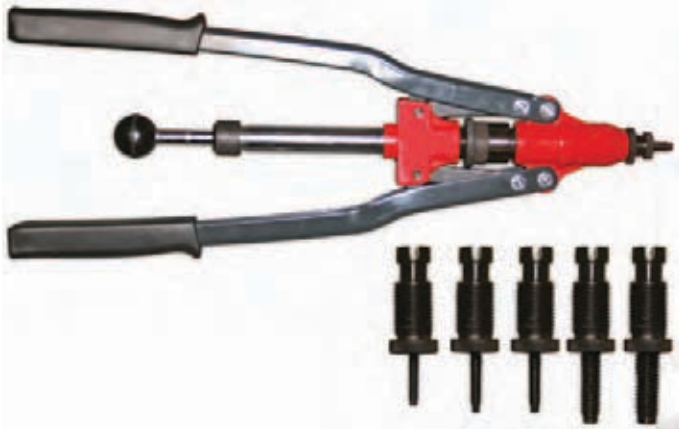

Includes	Art #
8-32, 10-24, 10-32, 1/4"-20, 5/16"-18 and 3/8"-16 mandrels	1917300

Sold Separately	Art #
8-32 mandrel	091704236
10-24 mandrel	091704237
10-32 mandrel	091704241
1/4"-20 mandrel	091704238
5/16"-18 mandrel	091704239
3/8"-16 mandrel	091704240
8-32 nose piece	091704241
10-24/10-32 nose piece	091704242
1/4"-20 nose piece	091704243
5/16"-18 nose piece	091704244
3/8"-16 nose piece	091704245

Total installation time 11 seconds!



LONG ARM RIVETER



- The long arms reduce the effort required to set rivets up to 1/4"
- Ideal for auto work, boat building, machine maintenance, etc.
- Supplied with 4 interchangeable noses
- The most powerful hand riveter available

Description	Art #
Long Arm Riveter	0949120

RIVET NUT TOOL WITH STANDARD MANDRELS

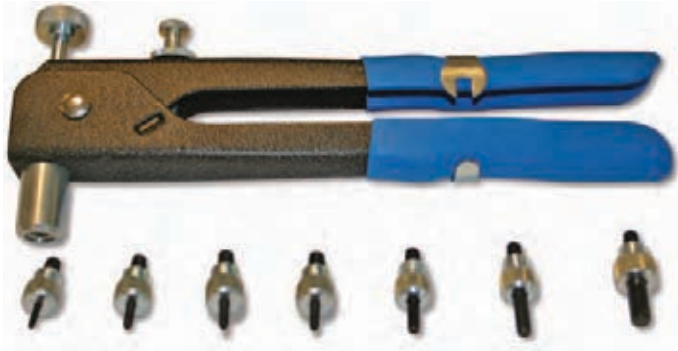

A lightweight but rugged tool for installing Rivet-nuts up to 3/8-16 in aluminum and 1/4-20 in steel. US mandrels included are 6-32, 8-32, 10-24, 10-32, 1/4-20, 5/16-18, 3/8-16.

- Sets Rivet-nuts in one stroke
- Clear sleeve for storage
- Easy install and removal of mandrels
- No fitter and assembler should be without it

Description	Art #
Rivet Nut Tool with Standard Mandrels	19175510

Replacement Mandrels	Art #
6-32 mandrel	19176321
8-32 mandrel	19178321
10-24 mandrel	191710241
10-32 mandrel	191710321
1/4"-20 mandrel	191714201
5/16"-18 mandrel	1917516181
3/8"-16 mandrel	191738161

RIVET NUT TOOL WITH METRIC MANDRELS

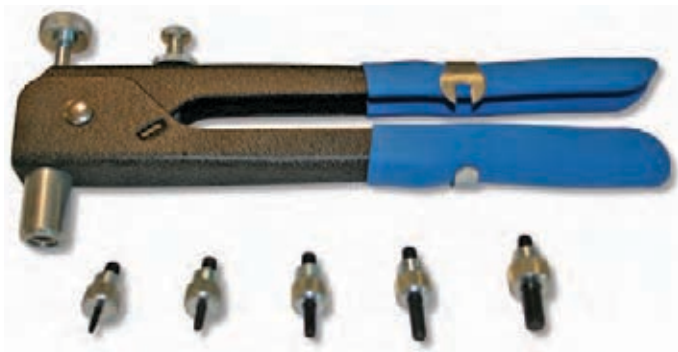

A light weight but rugged tool for installing Rivet-nuts up to 8mm. Metric mandrels included are 3mm, 4mm, 5mm, 6mm, 8mm.

- Sets Rivet-nuts in one stroke
- Clear sleeve for storage
- Easy install and removal of mandrels
- No fitter and assembler should be without it

Description	Art #
Rivet Nut Tool with Metric Mandrels	191755102

Replacement Mandrels	Art #
3mm mandrel	091713
4mm mandrel	091714
5mm mandrel	091715
6mm mandrel	091716
8mm mandrel	091718

ZEBRA FLEX DRIVERS



- Shaft: Round, flexible
- Drive: For hex head screws
- Head: Bright nickel-plated, interior bore for protruding heads
- DIN 3125
- Use in tight spaces, hose clamps

Socket Dia. mm	Shaft Length mm	Head Length mm	Head Width mm	Overall Length mm	Art #
5	150	96	31	6"	061328605
6	150	96	31	6"	061328606
7	150	106	35	6"	061328607
8	150	106	35	6"	061328608

WURTH AIR WEDGE



Inflatable lockout wedge

- Slim design, only 1/16" thick deflated, 2-3/4" maximum inflated
- Will not scratch trim pieces or damage paint or glass
- Easy to adjust air pressure by pressing relief button
- Sturdy plastic envelope is tightly sealed and cannot be over-inflated
- Air Pressure: 220-440 psi
- Reinforced man-made material

Description	Art #
Air Wedge	07156780



NOTE: Inflate the Air Wedge with care. WURTH cannot be held responsible for any direct or indirect damages to the user or vehicle.

BRAKE FLUID TESTER



- 5 LED's for accurate indication of water content in the brake fluid in stages of 0%, <1%, approx. 2%, approx. 3%, >4%
- TUV certified for safety
- Robust with protective cap for professional use
- Small and handy, always ready for use
- For use in car, truck and motorcycle workshops and in service areas
- Battery included

Description	Art #
Brake Fluid Tester	071553200
Replacement Battery	071553201

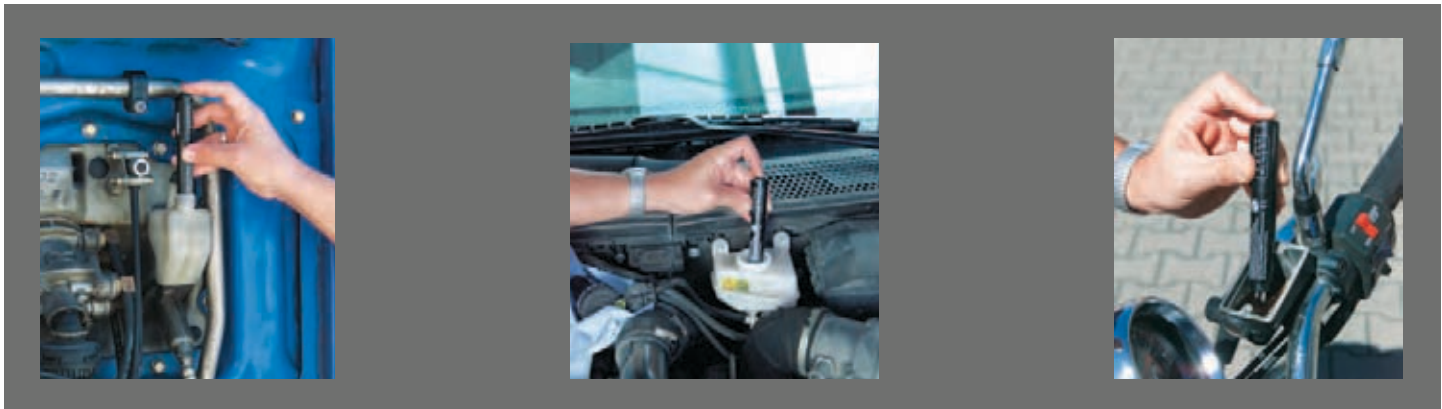

6" DIGITAL CALIPER



- Does both metric and standard
- Comes with hard plastic carrying case

Description	Art #
6" Digital Caliper	07157619
Replacement Battery	0827085351

CRIMP CLAMP TOOL



Description	Art #
Crimp Clamp Tool	154102541



Crimp Clamp Tool can be used on Ear Clamps

BODY & FENDER DENT PULLING SYSTEM



Features

- No removal of paint coating - **No repainting**
(The success of the repair without repainting depends on the quality of the paint and how the product is used)
- No disassembly of the interior trim and no disconnection of the battery - **No disassembly/assembly times**
- No welding burns on the inner side of the body - **No reworking required**
- The low generation of heat allows work even on critical components
Universal application, e.g. on motorcycle fuel tanks, stainless steel containers etc
- The large-surface adapters enable smooth straightening of the dent -
No reworking required compared to spot welding methods

Application of the Adapters

- Five different tension adapters included in the set enable optimized work on small, large, round or long dents.
- The adapters can be reused and trimmed.

Application on the following materials

- Painted surfaces
- Steel sheet, blank or galvanized
- Stainless steel
- Aluminum
- Sheet gauges from 0.5 to 2mm

By attaching the tension adapters, dents in different materials and surfaces can be pulled out. Subsequent painting of many dents may not be needed.

WURTH Patented Product

Description	Art #
Body & Fender Dent Pulling System	0691500111

Includes			
#	Description	Qty	Art #
1	Slide Hammer	1	0691500112
2	Glue Sticks	24	0890100057
3	Adapter - round, stiff, yellow	10	0691500115
4	Adapter - round, flexible, purple	10	0691500116
5	Adapter - oval, stiff, yellow	10	0691500117
6	Adapter - oval, flexible, purple	10	0691500118
7	Adapter - round, small, blue	10	0691500121
8	Lifter for Adapter	1	0691500114
9	Spreader - blue	2	0691500120
10	Clean Prep	1	08909380
11	Electric Glue Gun	1	0702100057
12	Scuff Pads	3	158544003
13	WURTH Gloves	1 pair	089941009
14	Low Lint Wipes	75	0899800901
	WURTH Freeze Spray (not included)		18909902

Notice

Do Not Apply Adapters To Hot Surface.



Freeze Spray
Art. # 1890 9902
(Sold Separately)

MAXI LIFT



Description	Art #
Maxi Lift	0691500140
Adapter Bolt (sold separately)	0691500141

- One hand operation permits hammer work on boundary of dent
- Excellent for roof & trunk repairs



MINI LIFTER KIT



Description	Art #
Mini Lifter Kit	0691500252

Includes				
#	Description	In Kit	Qty	Art #
1	Mini Lifter Tool	1	1	0691500180
2	Special Glue Stick	10 pcs	10 pcs	0890100050
3	Adapter Ball Shaped	16 mm	5 pcs	0691500160
	Adapter Ball Shaped	21 mm	5 pcs	0691500161
4	Adapter Ball Shaped	27 mm	5 pcs	0691500162
	Adapter Ball Shaped	32 mm	5 pcs	0691500163
5	Contact Feet	1 pair	1 pair	0691500156
6	Wedged Scraper	1	1	07145832
7	Straightening Cone	1	1	0691500150
8	Gloves	1 pair	1 pair	089941009
9	Cleaning Cloths	1 pack	75	0899800901
	Clean Prep	not included	3	08909380
	WURTH Freeze Spray	not included	3	18909902
10	19" Tool Box	1	1	1695590651

The Mini Lifter is especially suitable for repairing small, soft dents on various materials.

Features

- Small, light and very handy, easy to use tool
- The contact feet can be set precisely on the dent so the edge of the dent is not pulled up
- The special swiveling contact feet adapt to any contour for optimal support and gentle treatment of surface finish
- Reverse deformation can be verified by the scale on the tool, assuring controlled reverse deformation of the dent
- Advanced adapters with ball shape and improved bonding surface, assuring best possible work results when repairing small dents

WURTH Patented Product

Note

The adapters Art. # 0691 500154 & 155 also fit the Dent Lifter and Maxi Lifter. However, the Dent Lifter Art. # 0691 500115-122 cannot be inserted in the Mini Lifter.



1/4" ANGLE HEAD DIE GRINDER



- Positive grip - 1/4" capacity collet chuck
- Lever throttle for feathering control
- Compact and lightweight
- Built-in regulator
- Front exhaust

Description	Art #
1/4" Angle Head Die Grinder	1703000875

Specifications	
Collet Size	1/4"
Free Speed	20,000 rpm
Overall Length	5"
Net Weight	1 lb.
Motor	1/3 hp
Air Inlet Thread NPT	1/4"
Air Hose I.D. Size	3/8"
Average Air Consumption	3 cfm
Air Pressure	90 - 120 PSI
Sound Pressure	92.3 dB(A)
Sound Power	103.7 dB(A)

DRS 3/8" WURTH AIR RATCHET



- Precision planet gear for highest power transmission and long service life
- Speed adjustable with integrated controller
- Recessed forward/reversed switch to prevent inadvertent operation
- Rubber seal at ratchet head prevents penetration of dirt
- 2 years warranty on material and manufacturing defects
- 1 Year Limited Warranty

Description	Art #
DRS 3/8" WURTH Air Ratchet	07038380

VARIO DRILL

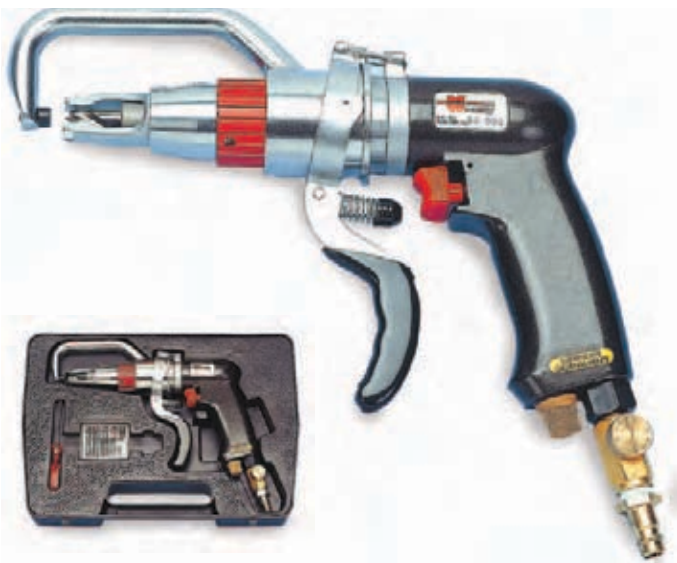

Features:

- For fast and easy removal of spot welds
- Contact pressure frame can be turned 360° and prevents slip-off. It enables easy working even in inaccessible places.
- Contact pressure frame can be assembled quickly without additional tools
- Cutting depth is infinitely variable and is not effected by the contact pressure frame
- Only use original HSCO weld point cutters
- 1 year warranty

Description	Art #
Vario Drill	1703090

Set Includes	Qty.
Vario Drill VD 90	1
Hex Head Socket	1
Cobalt Cutter 6mm	1
Cobalt Cutter 8mm	3
Cobalt Cutter 9mm	1

Specifications	
Speed	1,300 rpm
Air Pressure	6 to 8 bar
Weight	Approx. 4 lbs.
Air Consumption	250 l/min.

VARIO POINT CUTTERS

Titanium HSCO/TIN

- No need for centre-punching
- Service life enhanced by a factor of between 2 and 3
- High cutting speed

Size	Art #
6 mm	0710606
8 mm	0710808
9 mm	0710909

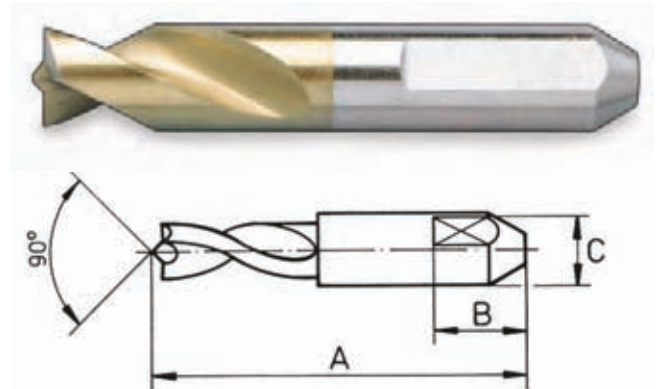

Cobalt HSCO

- No need for centre-punching

Size	Art #
6 mm	071060
8 mm	071080
9 mm	071090

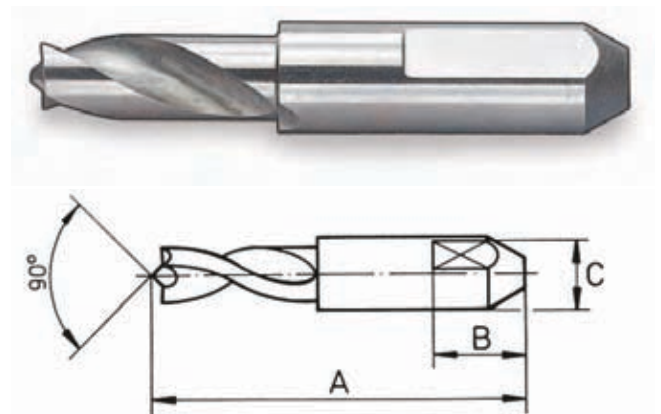

Spottle Gun Cobalt HSCO

- No need for centre-punching

Size	Art #
8 mm	0710081

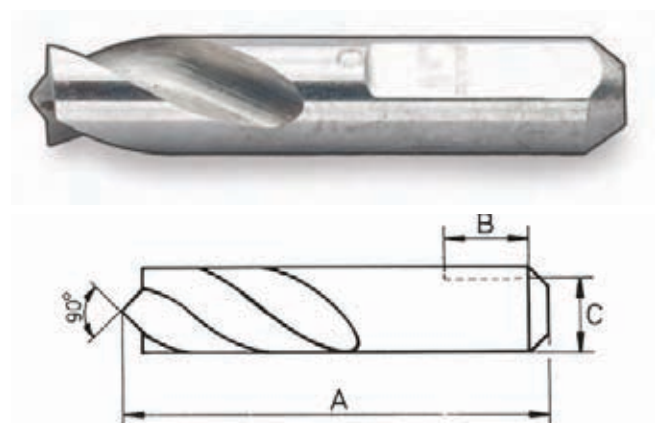

ZEBRA WELD POINT CUTTER

For High Strength Metals Such As Boron

- Suitable for Vario Drill

Size	Art #
8 mm	07108080

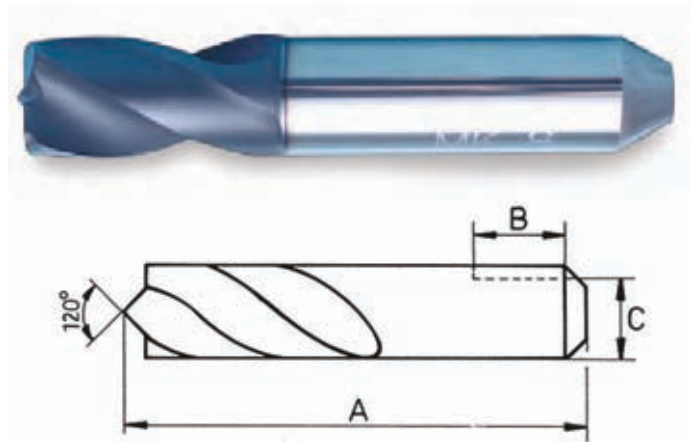

For High Strength Metals Such As Boron

- Suitable for drills with pneumatic advance (screw -nail drill)

Size	Art #
8 mm	07108081

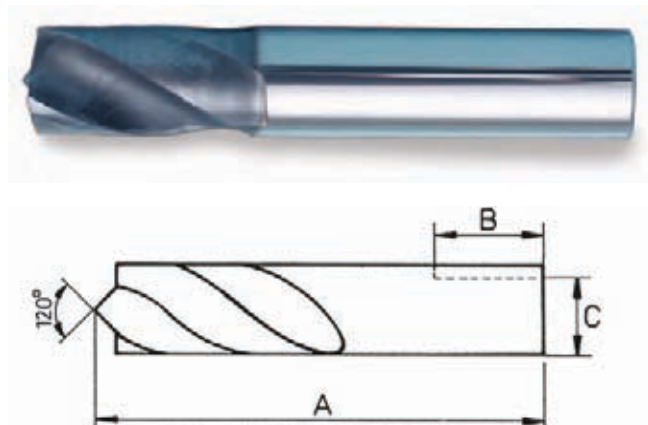

AIR SANDERS

- Excellent for finish sanding
- Can use with Hutchins style 6 hole paper
- Lightweight 3.6 lbs
- Speed control on top of casing
- Quiet vibration-free operation
- Ergonomic design for tireless working
- 1 year warranty

Description	Art #
Sander	0703761
Bag & Hose	07037613



Backing Pads	Holes	Art #
6" Velcro Back	6 holes	0586960001
6" Velcro Back	No holes	0586960004
6" Self Adhesive Back	6 holes	0586960101
6" Self Adhesive Back	No holes	0586960104

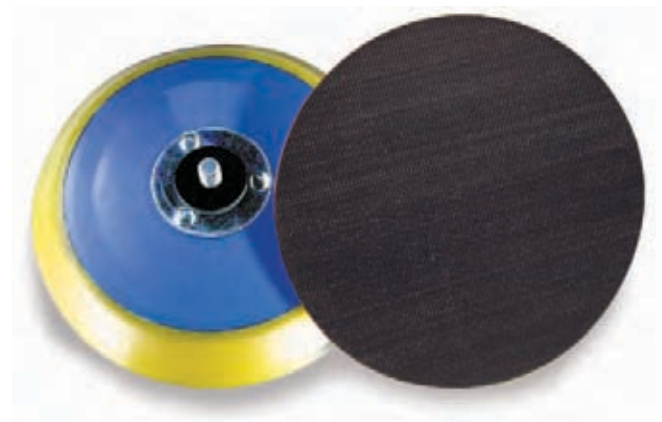

DBS 3600

Description	Art #
DBS 3600 Kit	07033601

Description	Art #
DBS 3600 Brush Grinder (1)	07033600
Adaptor - 11mm (1)	070336021
Adaptor - 23mm (1)	07033602
Holder for black strip wheel double (1)	070336022
Holder for black strip wheel single (1)	070336023
11mm Fine Brush (1)	070335031
23mm Fine Brush (1)	17033503
11mm Coarse Brush (1)	070335051
23mm Coarse Brush (1)	17033501
Rubber Eraser (1)	158591
Rubber Eraser - Water Based Paint (1)	058596
Black Strip Wheel (2)	05851100

New and Improved!

Special material with heat treatment on entire wire -for longer life.

Rubber safety flap for improved protection during use.

Stronger structure design on the rubber eraser offers better stability and longevity (eraser for water based paint is also now available).

Single and double wheel are both available for applications.

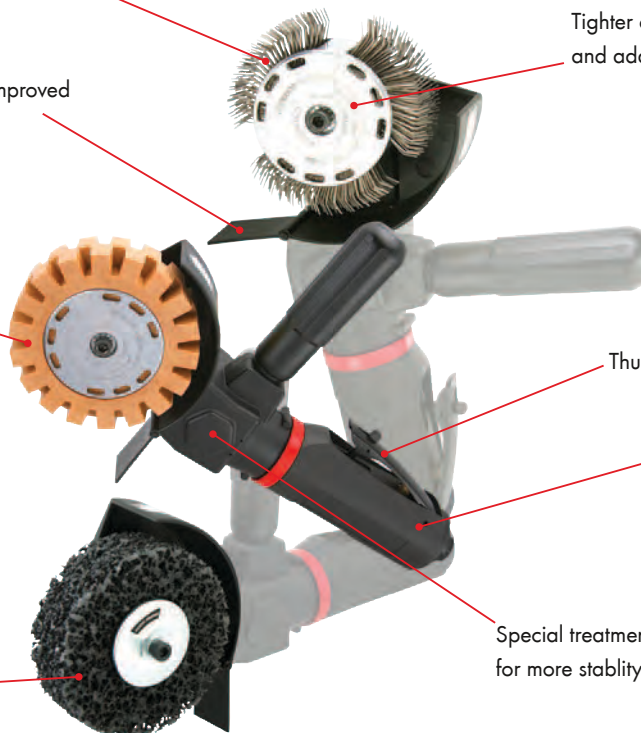

Tighter contacting between the wire brush and adaptor - no bending wire while in use.

Thumb-activated for better control.

Professional rubber-coated handle grip for comfort and less vibration.

Special treatment on the bevel gear for more stability and longer lifetime.

NIPPLE INTERCHANGE CHART - COUPLER

1/4" Lincoln Long Nose Series Type "A"							
Description	AMFLO	Milton	Truflate	NAPA	Lincoln	Foster	Art #
Male 1/4" NPT Steel	C27	790	13-424	90-645	N/A	LN3103	169960014
Female 1/4" NPT Steel	C28	N/A	13-434	90-644	815	LN3003	169971014



1/4" ARO Series Type "B"							
Description	AMFLO	Milton	Truflate	NAPA	Lincoln	Foster	Art #
Male 1/4" NPT Steel	C37	N/A	13-324	90-614	N/A	210-3103	169967014
Female 1/4" NPT Steel	C38	N/A	13-334	90-612	862	N/A	169967114
Economy Female 1/4" NP Brass	C38B	N/A	N/A	N/A	N/A	N/A	1699941406



1/4" Automotive Standard Series Type "C" Truflate							
Description	AMFLO	Milton	Truflate	NAPA	Lincoln	Foster	Art #
Male 1/4" NPT Steel	C1	786	13-125	90-610	N/A	TF3103	169961014
Female 1/4" NPT Steel	C2	785	13-134	90-600	N/A	TF3003	169961114



3/8" Automotive Standard Series Type "G"							
Description	AMFLO	Milton	Truflate	NAPA	Lincoln	Foster	Art #
Female 1/4" NPT Steel	C8	1803	13-610	90-686	N/A	TF4004	169962114
Female 3/8" NPT Steel	C6	1805	13-612	90-654	N/A	TF4204	169962138

1/2" Automotive Series Type "F"							
Description	AMFLO	Milton	Truflate	NAPA	Lincoln	Foster	Art #
Male 1/2" NPT Steel	C9	1816	13-704	90-664	651008	5305	169963112
Female 1/2" NPT Steel	C10	1815	13-712	90-662	652008	5205	169963012

NIPPLE INTERCHANGE CHART - COUPLER (CONTINUED)

1/4" Industrial Series Type "D" Milton							
Description	AMFLO	Milton	Truflate	NAPA	Lincoln	Foster	Art #
Male 1/4" NPT Steel	C21	716	13-224	90-672	611004	3103	169964014
Female 1/4" NPT Steel	C20	715	13-234	90-670	612004	3003	169964114
Economy Female 1/4" NPT Brass	C20B	N/A	N/A	N/A	N/A	N/A	1699941405
Female 3/8" NPT Steel	C20-23	718	13-236	N/A	612006	3203	169964138
Hose Barb 1/4" Steel	C20-42	N/A	N/A	N/A	N/A	N/A	169964214
Hose Barb 3/8" Steel	C20-44	N/A	N/A	N/A	N/A	N/A	169964238
3/8" Industrial Series Type "E"							
Description	AMFLO	Milton	Truflate	NAPA	Lincoln	Foster	Art #
Male 3/8" NPT Steel	C25	1836	13-526	90-682	641006	4304	169965038

1/4" Diamond-U Series							
Description	AMFLO	Milton	Truflate	NAPA	Lincoln	Foster	Art #
Male 1/4" NPT Steel	C31	N/A	N/A	N/A	N/A	N/A	169970014



NIPPLE INTERCHANGE CHART - NIPPLE
1/4" Lincoln Long Nose Series Type "A"

Description	AMFLO	Milton	Truflate	NAPA	Lincoln	Foster	Art #
Male 1/4" NPT Steel	CP27	791	12-424	90-648	11659	LN10	1699921409
Female 1/4" NPT Steel	CP28	792	12-434	90-650	11661	LN11	1699092014

1/4" ARO Series Type "B"

Description	AMFLO	Milton	Truflate	NAPA	Lincoln	Foster	Art #
Male 1/4" NPT Steel	CP37	777	12-324	90-618	13329	210-10	1699921114
Female 1/4" NPT Steel	CP38	778	12-334	90-620	13331	210-11	1699931114

1/4" Automotive Standard Series Type "C" Truflate

Description	AMFLO	Milton	Truflate	NAPA	Lincoln	Foster	Art #
Male 1/4" NPT Steel	CP1	783	12-124	90-626	N/A	TF10	1699013452
Male 3/8" NPT Steel	CP1-03	N/A	N/A	N/A	N/A	N/A	1699013038
Female 1/4" NPT Steel	CP2	784	13-134	90-600	N/A	TF11	1699013402

3/8" Automotive Standard Series Type "G"

Description	AMFLO	Milton	Truflate	NAPA	Lincoln	Foster	Art #
Male 1/4" NPT Steel	CP7	1809	12-602	90-685	N/A	TF40	1699023014
Male 3/8" NPT Steel	CP5	1807	12-604	90-658	N/A	TF42	1699023038
Female 3/8" NPT Steel	CP8	1810	12-610	90-687	N/A	TF41	1699022014

1/2" Automotive Series Type "F"

Description	AMFLO	Milton	Truflate	NAPA	Lincoln	Foster	Art #
Male 1/2" NPT Steel	CP17	1817	12-704	90-666	630204	54-5	1699063012
Female 1/2" NPT Steel	CP18	N/A	N/A	N/A	N/A	N/A	1699062012

NIPPLE INTERCHANGE CHART - NIPPLE

1/4" Industrial Series Type "D" Milton							
Description	AMFLO	Milton	Truflate	NAPA	Lincoln	Foster	Art #
Male 1/4" NPT Steel	CP21	727	12-224	90-674	630104	10-3	16999214
Female 1/4" NPT Steel	CP20	728	12-234	90-676	630204	11-3	16999314
Female 3/8" NPT Steel	CP20-23	732	N/A	N/A	630106	15-3	16999238
Hose Barb 1/4" Steel	CP21-42	N/A	N/A	N/A	N/A	N/A	1699040014
Hose Barb 3/8" Steel	CP21-44	N/A	N/A	N/A	N/A	N/A	1699040038
3/8" Industrial Series Type "E"							
Description	AMFLO	Milton	Truflate	NAPA	Lincoln	Foster	Art #
Male 1/4" NPT Steel	CP25-02	1839	N/A	N/A	640104	40-4	1699053014
Female 1/4" NPT Steel	CP25	1837	12-526	90-683	640106	42-4	1699102014

IDENTIFICATION CHART - 1/4" COUPLERS

INDUSTRIAL

AUTOMOTIVE

ARO

LINCOLN

DIAMOND-U

IDENTIFICATION CHART - 1/4" PLUG

INDUSTRIAL

AUTOMOTIVE

ARO

LINCOLN

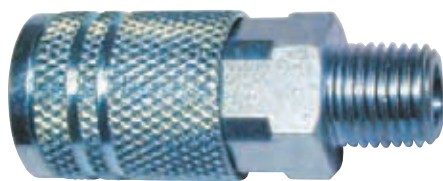
DIAMOND-U
IDENTIFICATION CHART - MALE, FEMALE & HOSE BARB

C21

C20

C20-44

CP1

CP10

CP21-44
MALE
FEMALE
HOSE BARB

SWING AIR COUPLER



- Safely connect and disconnect under pressure
- In accordance with ISO 6150, safety standard ISO 4414 and MILC 4109
- Full flow
- Easy to operate, easy to clean
- Compact design with few individual parts
- Ergonomic design, quality engineered
- Simultaneous venting reduces the dangerous whiplash effect
- Partly covered coating for protection

Use with:	Art #
Milton Short Nipple	069996141
Milton Long Nipple	0699961141



CONNECT

SWING

FULL FLOW

WÜRTH COUPLERS

- Made from a polyamide composite material, inside and out, that is stronger than brass and steel
- Designed to withstand high impact and repetitive motion
- Materials are guaranteed against defects in workmanship and have a 1 year no leak warranty under normal working conditions

Description	Use with:	Art #
Safety 1/4" NPT Female	1/4" Industrial Type "D" Milton Nipple Profile	169992001
Standard 1/4" NPT Female	1/4" Industrial Type "D" Milton Nipple Profile	169992002



Safety 1/4" NPT Female



Standard 1/4" NPT Female

HIGH FLOW QUICK DISCONNECT COUPLER & NIPPLES

- Extremely high flow capacity, 74.1 CFM at 87 PSI
- Easy one hand assembly and disassembly
- One way shut-off
- Especially suitable for HVLP paint guns

Description	Art #
1/4" Coupler	169994014
1/4" Male Nipple	169992014
1/4" Female Nipple	169993014



SAFETY AIR COUPLER - TRUFLATE

Description	Use with:	Art #
1/4" NPT Female	Truflate Nipple Profile	169992201



BLUE PUSH BUTTON COUPLER

Description	Use with:	Art #
1/4" NPT Female	Industrial Nipple Profile	0699714
1/4" NPT Female	ARO Nipple Profile	0699715



UNIVERSAL COUPLER

- Easy, one hand assembly/disassembly
- High flow capacity
- Heavy duty, made in Sweden

Description	Art #
1/4" NPT Female	169994141
3/8" NPT Female	169994381

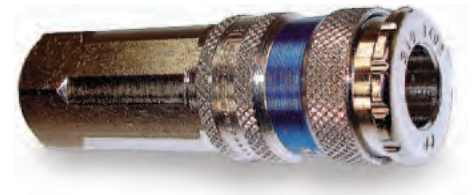

Fits these air nipples



ARO 210 Series



Industrial Series

AIR COUPLERS: COLORCONNEX®

Type D	Type C	Type B	Type J	Type G
1/4" Series	1/4" Series	1/4" Series	3/8" Series	3/8" Series
Industrial	Automotive	ARO	ARO	Automotive

WURTH USA's Color Code System for Standard Interchanges

This unique system allows for easy, color-to-color matching of couplers and plugs among the standard pneumatic interchanges. It also solves the problem of potential crossing and contaminating of different air lines.

Type and Series is easily identified by its color!

- Match coupler and plug types by color
- Dedicate hose applications to ensure a lubricated (wet) line is never used for a dry line application!
- 3/8" Series Couplers & Plugs for High CFM Requirements

As air line interchanges become popular in the automotive industry, some of the different manufacturers developed their own styles in an attempt to capture the market. As a result, various incompatible, yet nearly identical-looking types emerged. To be able to recognize each type, one would have to memorize the brands on all the coupler sleeves and the shapes of all plugs.

AIR COUPLERS: COLORCONNEX® (CONTINUED)

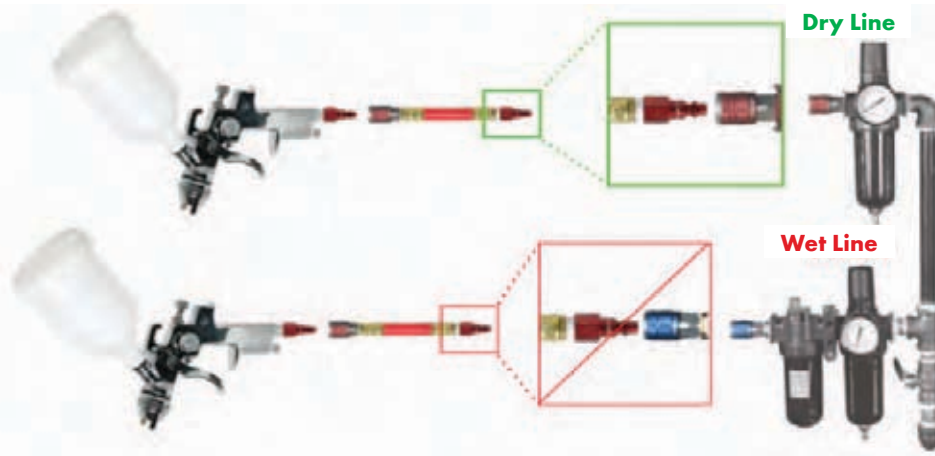

Dedicate Hose Applications

By using color to dedicate your different air lines, a lubricated line will never be used for a dry line application as long as our couplers and plugs match. As shown in the example image, the red and blue color types are used to distinguish the separate lines, preventing the paint gun from accidentally being connected to the wet line, and therefore contaminating the paint with oil as it is being applied.

3/8" COUPLERS & PLUGS - FOR HIGH CFM REQUIREMENTS

Black - Type G - Automotive	
Description	Art #
Type G Automotive 3/8" body, 3/8" FNPT sleeve coupler	16992038
Type G Automotive 3/8" body, 3/8" MNPT sleeve coupler	16991938
Type G Automotive 3/8" body, 3/8" FNPT plug	169902038
Type G Automotive 3/8" body, 3/8" MNPT plug	169902138

Gold - Type J - ARO	
Description	Art #
Type J ARO 3/8" body, 3/8" FNPT sleeve coupler	1699071438
Type J ARO 3/8" body, 3/8" MNPT sleeve coupler	1699171438
Type J ARO 3/8" body, 3/8" FNPT plug	1699101438
Type J ARO 3/8" body, 3/8" MNPT plug	1699111438



1/4" SERIES COUPLERS & PLUGS

Green - Type B - ARO	
Description	Art #
Type B ARO 1/4" body, 1/4" FNPT sleeve coupler	1699267114
Type B ARO 1/4" body, 1/4" MNPT sleeve coupler	1699167014
Type B ARO 1/4" body, 1/4" FNPT plug	1699093114
Type B ARO 1/4" body, 1/4" MNPT plug	1699092114



1/4" SERIES COUPLERS & PLUGS (CONTINUED)

Blue - Type C - Automotive	
Description	Art #
Type C Automotive 1/4" body, 1/4" FNPT sleeve coupler	1699261114
Type C Automotive 1/4" body, 1/4" MNPT sleeve coupler	1699261014
Type C Automotive 1/4" body, 1/4" FNPT plug	1699201340
Type C Automotive 1/4" body, 1/4" MNPT plug	1699201345



Red - Type D - Industrial	
Description	Art #
Type D Industrial 1/4" body, 1/4" FNPT sleeve coupler	1699264114
Type D Industrial 1/4" body, 1/4" MNPT sleeve coupler	1699164014
Type D Industrial 1/4" body, 1/4" FNPT plug	169929314
Type D Industrial 1/4" body, 1/4" MNPT plug	169929214



AIR COUPLERS: INDUSTRIAL (1/4")

Industrial Series

- High Quality Fittings
- Plated Steel Couplers Have Hardened Balls
- Stainless Steel Springs
- Heat Treated To Reduce Wear
- Long Life Durability
- Rated At 300 psi
- Can Be Used With Popular Brands
- Other Sizes & Types Available

Industrial Series		
Description	Type	Art #
1/4" NPT Female	C20	169964114
3/8" NPT Female	C20-23	169964138

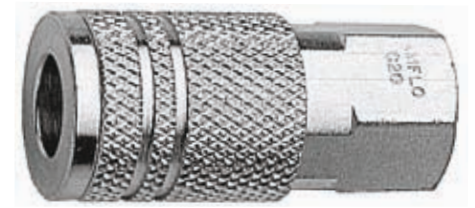

1/4" Series NPT Female Pipe Thread

Industrial Series		
Description	Type	Art #
1/4" Hose Barb	C20-42	169964214



1/4" Series - Couplers		
Description	Type	Art #
1/4" NPT Male	C21	169964014

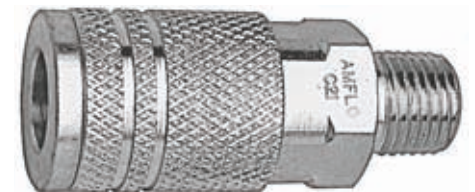

1/4" Series NPT Male Pipe Thread

1/4" Series - Couplers		
Description	Type	Art #
1/4" Hose Barb	CP21-42	1699040014



1/4" Series Standard Hose Barb

1/4" Series - Couplers		
Description	Type	Art #
1/4" NPT Female	CP28	1699092014



1/4" Series NPT Female Pipe Thread

AIR COUPLERS: TRU-FLATE (1/4")

Automotive Series Tru-Flate

- High Quality Fittings
- Plated Steel Couplers Have Hardened Balls
- Stainless Steel Springs
- Heat Treated To Reduce Wear
- Long Life Durability
- Rated At 300 psi
- Can Be Used With Popular Brands
- Other Sizes & Types Available

1/4" Series - Plugs		
Description	Type	Art #
3/8" NPT Male	CP1-03	1699013038

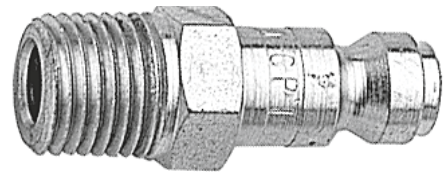

Tru-Flate 1/4" Series NPT Male Pipe Thread

1/4" Series - Couplers		
Description	Type	Art #
1/4" NPT Male	C1	169961014

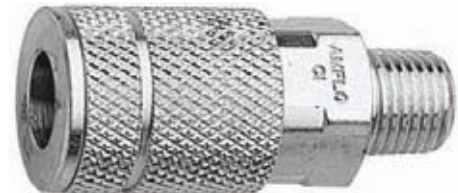

1/4" Series - Couplers		
Description	Type	Art #
1/4" NPT Female	C2	169961114



1/4" Series NPT Female Pipe Thread

1/4" Series - Couplers		
Description	Type	Art #
1/4" NPT Male	C27	169960014



1/4" Series NPT Male Pipe Thread

AIR COUPLERS: INDUSTRIAL (3/8")
3/8" Series - Plugs

Description	Type	Art #
3/8" NPT Male	CP5	1699023038
1/4" NPT Male	CP7	1699023014

3/8" Series NPT Male Pipe Thread
3/8" Series - Plugs

Description	Type	Art #
1/4" NPT Female	CP8	1699022014

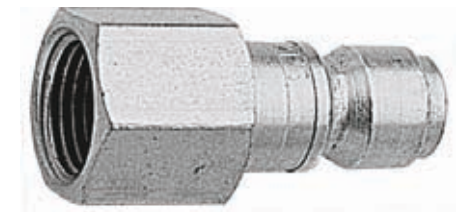
3/8" Series NPT Female Pipe Thread
3/8" Series - Couplers

Description	Type	Art #
3/8" NPT Female	C6	169962138
1/4" NPT Female	C8	169962114

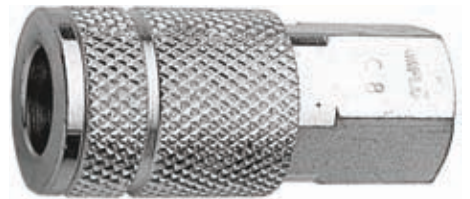
3/8" Series NPT Female Pipe Thread
AIR COUPLERS: TRU-FLATE (3/8")
3/8" Series - Plugs

Description	Type	Art #
3/8" NPT Male	CP25	1699053038
1/4" NPT Male	CP25-02	1699053014

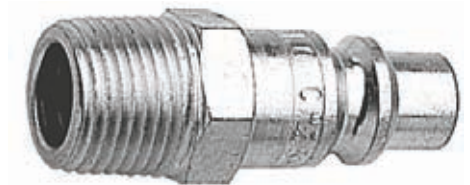
3/8" Series NPT Male Pipe Thread
3/8" Series - Couplers

Description	Type	Art #
3/8" NPT Male	C25	169965038

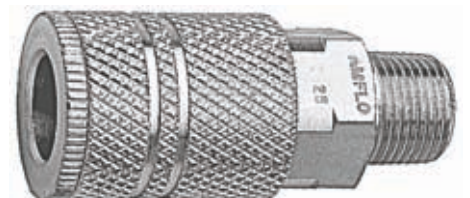

3/8" Series NPT Male Pipe Thread

AIR COUPLERS: INDUSTRIAL (1/2")
1/2" Series - Plugs

Description	Type	Art #
1/2" NPT Male	CP17	1699063012

1/2" Series NPT Male Pipe Thread
1/2" Series - Plugs

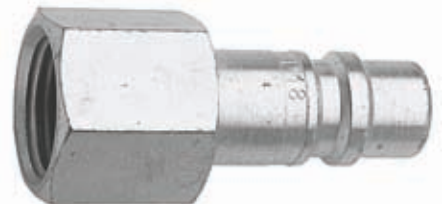
Description	Type	Art #
1/2" NPT Female	CP18	1699062012

1/2" Series NPT Female Pipe Thread
AIR COUPLERS: TRU FLATE (1/2")
1/2" Series - Couplers

Description	Type	Art #
1/2" NPT Male	C9	169963012



1/2" Series NPT Male Pipe Thread
1/2" Series - Couplers

Description	Type	Art #
1/2" NPT Female	C10	169963112

1/2" Series NPT Female Pipe Thread

AIR HOSE ACCESSORIES
Male Thread Fittings - BARBED (Solid Brass)

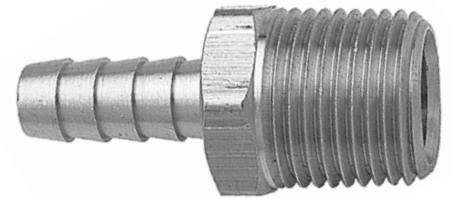
Thread Size	Hose I.D.	Type	Art #
1/4" NPT	1/4"	401	1699451414
1/4" NPT	3/8"	406	1699453814
3/8" NPT	3/8"	606	1699453838
1/2" NPT	3/8"	806	1699453812

Male Swivel Fittings - BARBED (Solid Brass)

Thread Size	Hose I.D.	Type	Art #
1/4" NPT	3/8"	606S	1699463838

Hi-Volume Male Fittings (Solid Brass)

Thread Size	Hose I.D.	Type	Art #
1/4" NPT	3/8"	406S	1699473814

Female Thread Fittings - BARBED

Thread Size	Hose I.D.	Type	Art #
1/4" NPT	3/8"	461	1699443814

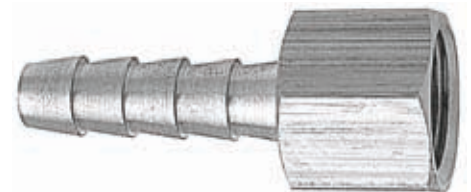
Barbed Splicers

Hose I.D.	Type	Art #
5/16"	502	1699450516
3/8"	602	169945038



AIR HOSE ACCESSORIES (CONTINUED)

Use these brass ferrules with standard hose barb fittings. To select correct ferrule, match ferrule I.D. and your hose O.D. as closely as possible.

Brass Ferrules

Ferrule I.D.	Type	Art #
5/8"	7327	169903141
23/32"	7330	169903381
1/2"	7323	169903122
11/16"	7329	1699031116
3/4"	7331	169903382

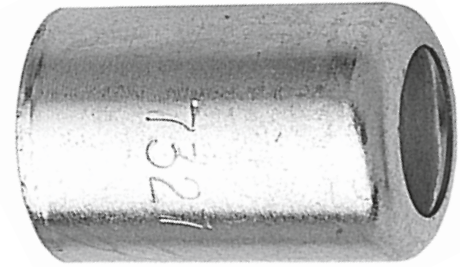

In-Line Accessories

Description	Art #
1/4" Inlet/Outlet	189116995



BRASS PIPE FITTINGS

X124

Extruded 45° Street Elbow	
Pipe	Art #
1/8"	1884057001
1/4"	1884057002
3/8"	1884057003
1/2"	1884057004



X115

Extruded 90° Street Elbow	
Pipe	Art #
1/8"	1884058001
1/4"	1884058002
3/8"	1884058003
1/2"	1884058004



X100

Extruded 90° Elbow	
Pipe	Art #
1/8"	1884059001
1/4"	1884059002
3/8"	1884059003
1/2"	1884059004



X101

Extruded Tee	
Pipe	Art #
1/8"	1884060001
1/4"	1884060002
3/8"	1884060003
1/2"	1884060004

BRASS DRAIN COCKS

240

Back Seating Type

Pipe	Art #
1/8"	1884096001
1/4"	1884096002

Ground Key Plug Type Lever Handle

Pipe	Art #
1/4"	1884074001

BRASS PIPE FITTINGS

118



119



108

Plug Hex Countersunk

Pipe	Art #
1/4"	1884089002
3/8"	1884089003
1/2"	1884089004

Reducing Coupling

Pipe	Art #
1/4" to 1/8"	1884083001
3/8" to 1/8"	1884083002
3/8" to 1/4"	1884083003

Cap

Pipe	Art #
1/8"	1884087001
1/4"	1884087002
3/8"	1884087003
1/2"	1884087004

BRASS PIPE FITTINGS (CONTINUED)

109

Plug Square Head	
Pipe	Art #
1/8"	1884088001
1/4"	1884088002
3/8"	1884088003
1/2"	1884088004



106

Plug Square Head	
Pipe	Art #
1/4"	1884086002
3/8"	1884086003



121

Plug Hex Head	
Pipe	Art #
cored 1/4"	1884090002
cored 3/8"	1884090003
cored 1/2"	1884090004



112

Close Nipple	
Pipe	Art #
1/8"	1884091001
1/4"	1884091002
3/8"	1884091003
1/2"	1884091004



103

Coupling	
Pipe	Art #
1/8"	1884082001
1/4"	1884082002
3/8"	1884082003
1/2"	1884082004
3/4"	1884082005



110

Bushing	
Pipe	Art #
1/4" to 1/8"	1884084001
3/8" to 1/8"	1884084002
3/8" to 1/4"	1884084003
1/2" to 3/8"	1884084004
1/2" to 1/4"	1884084005
1/2" to 3/8"	1884084006
3/4" to 3/8"	1884084009
3/4" to 1/2"	1884084010

BRASS PIPE FITTINGS (CONTINUED)

122



113



120

Hex Nipple	
Pipe	Art #
1/8"	1884092001
1/4"	1884092002
3/8"	1884092004
1/2"	1884092007
Reducing	
1/4" to 1/8"	1884092008
3/8" to 1/4"	1884092009

Long Nipple		
Length	Pipe	Art #
1-1/2"	1/8"	1884093001
2"		1884093002
2-1/2"		1884093003
3"		1884093004
1-1/2"	1/4"	1884093007
2"		1884093008
3"		1884093010
1-1/2"	3/8"	1884093013
2"		1884093014
3"		1884093016
2"	1/2"	1884093020
2-1/2"		1884093021
3"		1884093022

Adapter	
Pipe	Art #
1/8" to 1/8"	1884085001
1/4" to 1/4"	1884085003
3/8" to 3/8"	1884085006
Reducing	
1/4" to 1/8"	1884085007
3/8" to 1/4"	1884085008
1/2" to 1/4"	1884085009
1/2" to 3/8"	1884085010

BRASS D.O.T. AIR BRAKE FITTINGS FOR S.A.E J844D NYLON TUBING



1469



1468



1466

90° Elbow-Tube to Male Pipe		
Tube	Pipe	Art #
1/4"	1/8"	1884041001
1/4"	1/4"	1884041002
1/4"	3/8"	1884041003
3/8"	1/8"	1884041004
3/8"	1/4"	1884041005
3/8"	3/8"	1884041006
3/8"	1/2"	1884041007
1/2"	1/4"	1884041008
1/2"	3/8"	1884041009
1/2"	1/2"	1884041010

Connector-Tube to Male Pipe		
Tube	Pipe	Art #
1/4"	1/8"	1884010001
1/4"	1/4"	1884010002
1/4"	3/8"	1884010003
3/8"	1/8"	1884010004
3/8"	1/4"	1884010005
3/8"	3/8"	1884010006
3/8"	1/2"	1884010007
1/2"	1/4"	1884010008
1/2"	3/8"	1884010009
1/2"	1/2"	1884010010

Connector-Tube to Female Pipe		
Tube	Pipe	Art #
1/4"	1/8"	1884081001
1/4"	1/4"	1884081002
3/8"	1/8"	1884081003
3/8"	1/4"	1884081004
3/8"	3/8"	1884081005
1/2"	3/8"	1884081006



1474



1471



1464

45° Elbow-Tube to Male Pipe		
Tube	Pipe	Art #
1/4"	1/8"	1884150001
1/4"	1/4"	1884150002
3/8"	1/4"	1884150003
3/8"	3/8"	1884150004
1/2"	3/8"	1884150005
1/2"	1/2"	1884150006

Tee-Ends Tube & Male Pipe Center Tube		
Tube	Pipe	Art #
3/8"	3/8"	1884071001
1/2"	3/8"	1884071002

Tee-Ends Tube Center Male Pipe		
Tube	Pipe	Art #
1/4"	1/8"	1884061001
1/4"	1/4"	1884061002
3/8"	3/8"	1884061004
1/2"	1/2"	1884061005

**BRASS D.O.T. AIR BRAKE FITTINGS FOR S.A.E J844D NYLON TUBING
(CONTINUED)**

1464



1477



1461

Tee-Tube Three Ends

Tube	Art #
1/4"	1884321001
3/8"	1884321002
1/2"	1884321003

Sleeve

Tube	Art #
1/4"	1884260001
3/8"	1884260002
1/2"	1884260003

Nut

Tube	Art #
1/4"	1884362001
3/8"	1884362002
1/2"	1884362003



1481

Brass Insert

Tube	Art #
1/4"	1884280001
3/8"	1884280002
1/2"	1884280003

BRASS PUSH-TO-CONNECT D.O.T. AIR BRAKE FITTINGS FOR S.A.E J844D NYLON TUBING

PC1474



PC1464



PC1470

45° Elbow-Tube to Male Pipe

Tube	Pipe	Art #
3/8"	1/4"	188505001
3/8"	3/8"	188505002

Union Tee-Tube Each End

Tube	Art #
1/4"	188502001
3/8"	188502002
1/2"	188502003

90° Elbow Tube to Female Pipe

Tube	Pipe	Art #
1/4"	1/8"	188503001

BRASS PUSH-TO-CONNECT D.O.T. AIR BRAKE FITTINGS FOR S.A.E J844D NYLON TUBING (CONTINUED)



PC1469



PC1462

90° Elbow-Tube to Male Pipe		
Tube	Pipe	Art #
5/32"	1/8"	1885030001
1/4"	1/8"	1885030002
1/4"	1/4"	1885030003
3/8"	1/4"	1885030006
3/8"	3/8"	1885030007
1/2"	3/8"	1885030008
1/2"	1/2"	1885030009

Union Coupling	
Tube	Art #
5/32"	188501001
1/4"	188501002
3/8"	188501003
1/2"	188501004

BRASS PUSH-TO-CONNECT D.O.T. AIR BRAKE FITTINGS FOR S.A.E J844D NYLON TUBING (CONTINUED)



PC1468



Connector-Tube to Male Pipe		
Tube	Pipe	Art #
5/32"	1/8"	188504001
1/4"	1/8"	188504002
1/4"	1/4"	188504003
1/4"	3/8"	188504004
3/8"	1/8"	188504005
3/8"	1/4"	188504006
3/8"	3/8"	188504007
3/8"	1/2"	188504008
1/2"	3/8"	188504010
1/2"	1/2"	188504011

S.A.E. - J844D Nylon Air Brake Tubing				
Outside Dia. I.D.	Wall Thickness	W.P. (PSI)	Reel Length (ft.)	Art #
Type 3B Reinforced				
3/8"	.062	350	100	1884148538
1/2"	.062	240	100	1884148512

BRASS D.O.T. AIR BRAKE FITTINGS FOR COPPER TUBING

1160



1161



1162

Sleeve

Tube	Art #
3/8"	1884261004

Nut

Tube	Art #
3/8"	1884363002

Union Coupling

Tube	Art #
1/4"	1884031001
1/2"	1884031003

90° Elbow Tube to Male Pipe

Tube	Pipe	Art #
3/8"	3/8"	1884032001

BRASS D.O.T. AIR BRAKE COUPLINGS

1490



1492



1493

Sleeve

Hose I.D.	Art #
3/8"	1884024001

Coupler Assembly (Nut, Sleeve, & Coupler)

Hose I.D.	Pipe	Art #
3/8"	3/8"	1884015002
1/2"	3/8"	1884015004

Coupler Assembly (Nut, Sleeve, & Coupler)

Hose I.D.	Pipe	Art #
3/8"	3/8"	1884023002

STEEL ONE PIECE CRIMP HOSE ENDS

- Use with medium to high pressure hydraulic hose



SCK 625



SCK 638

Male Pipe		
Hose I.D.	Pipe	Art #
1/2"	3/8"	1884094013

J.I.C. 37° Female Flare (swivel)		
Hose I.D.	Pipe	Art #
1/2"	1/2"	1884095016

BRASS S.A.E. 45° FLARE



42



48



49

Union Coupling-Tube to Tube	
Pipe	Art #
1/8"	1884043001
3/16"	1884043002
1/4"	1884043003
3/8"	1884043004

Union Coupling-Tube to Tube		
Tube	Pipe	Art #
1/4"	1/4"	1884044003
5/16"	1/8"	1884044006
5/16"	1/4"	1884044007
3/8"	1/8"	1884044008
3/8"	1/4"	1884044009
3/8"	3/8"	1884044010
1/2"	3/8"	1884044014
1/2"	1/2"	1884044015

90° Elbow Tube to Male Pipe		
Tube	Pipe	Art #
3/16"	1/8"	1884045001



54

45° Elbow Tube to Male Pipe		
Tube	Pipe	Art #
1/4"	1/8"	1884046001
3/8"	3/8"	1884046006

BRASS S.A.E. 45° INVERTED FLARE



149



5141



148

90° Tube to Male Pipe

Tube	Pipe	Art #
1/4"	1/8"	1884019002
1/4"	1/4"	1884019003
5/16"	1/8"	1884019004
3/8"	1/8"	1884019006
3/8"	1/4"	1884019007
3/8"	3/8"	1884019008

Steel Nut

Tube	Art #
1/8"	1884072001
3/16"	1884072002
1/4"	1884072003
5/16"	1884072004
3/8"	1884072005

Connector Tube to Male Pipe

Tube	Pipe	Art #
3/16"	1/8"	1884016001
1/4"	1/8"	1884016002



141



142



5L141

Brass Nut

Tube	Art #
3/16"	1884018001
1/4"	1884018002
5/16"	1884018003
3/8"	1884018004

Union Coupling-Tube to Tube

Tube	Art #
3/16"	1884017002
1/4"	1884017003
5/16"	1884017004
3/8"	1884017005

Steel Nut-Long Style

Tube	Art #
3/16"	1884073001
1/4"	1884073002

BRASS J.I.C. 37° FLARE



3748

Connector Tube to Male Pipe

Tube	Pipe	Art #
3/8"	1/8"	1884048004
3/8"	3/8"	1884048006

BRASS COMPRESSION FITTINGS

- No tube flaring necessary
- Manufactured for low and medium pressure work.
- Use Wurth Pipe Sealant Art. # 0893511050



64

Tee Tube Three Ends		
Tube		Art #
1/4"		1884051001
3/8"		1884051003
1/2"		1884051004



260

In-Line Sleeve		
Tube		Art #
1/8"		1884052001
3/16"		1884052002
1/4"		1884052003



68

Connector Tube to Male Pipe		
Tube	Pipe	Art #
3/16"	1/8"	1884053001
1/4"	1/8"	1884053002
1/4"	1/4"	1884053003
3/8"	1/4"	1884053006
3/8"	3/8"	1884053007

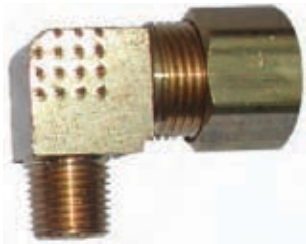

69

90° Elbow Tube to Male Pipe		
Tube	Pipe	Art #
1/8"	1/8"	1884054001
5/16"	1/8"	1884054002
3/8"	1/8"	1884054003
3/8"	1/2"	1884054004



60

Standard Sleeve		
Tube		Art #
1/8"		1884055001
3/16"		1884055002
1/4"		1884055003
5/16"		1884055004
3/8"		1884055005
1/2"		1884055006



62

Union Coupling		
Tube		Art #
1/8"		1884056001
3/16"		1884056002
1/4"		1884056003
5/16"		1884056004
3/8"		1884056005
1/2"		1884056006

AIR HOSE & ACCESSORIES

- Metal bowl with sightglass
- Compact and modern styling gives outstanding filtration performance
- 50 micron element standard
- 1/3 pint reservoir
- Inlet pressure 150 PSI maximum.

Airline Filters - 1/4" Basic Metal Bowl		
Part Size	Type	Art #
Manual Drain - 3/8"	4021A	1699031438

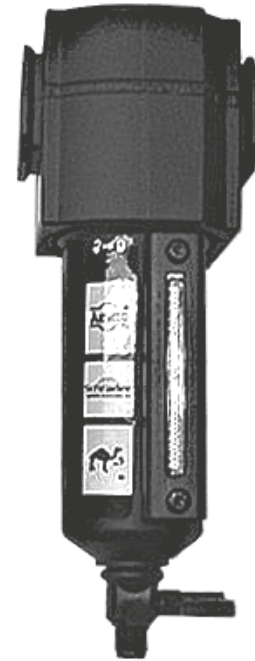

- Designed for use where performance is required in a minimum space
- Transparent bowl, 5-micron element standard
- Bowl guard not available with this model

Miniature Filter - 1/4" Basic		
Part Size	Type	Art #
1/4"	F07-200A	169903414



AIRLINE FILTERS & REGULATORS

- Metal bowl with sightglass
- Compact and modern styling gives outstanding filtration performance
- 50 micron element standard
- 1/2 pint reservoir
- Inlet pressure 150 PSI maximum

Airline Filters - 1/3" Basic Metal Bowl

Part Size	Type	Art #
Manual Drain - 1/2"	F74G-4M-MB	1699031612



Filter Regulator and Gauge

Part Size	Type	Art #
Automatic Drain - 1/2"	B74G-4AG-MB	169903310



AIR HOSE

- Lightweight, heavy duty hose with a 100% guarantee against defects in materials and workmanship for a full 2 years
- Never leave any airhose on the floor - damage and outer jacket swelling can occur from certain fluids
- 300 PSI working pressure
- 1,200 PSI burst pressure



Size	Length	Art #
1/4"	50 ft. roll	18951615
3/8"	25 ft. roll	18951415
3/8"	50 ft. roll	18951413

BLUE POLYURETHANE COIL AIR HOSE

- Ideal for pneumatic hand tool whip
- Lightweight, economical, small envelope size
- Swivel and rigid NPT connections
- Outperforms nylon assemblies
- Rated to 145 PSI operating pressure
- Temperature Range: -22°F to +140°F
- Will not mar surfaces

Length	Art #
19.5 ft.	16996395
26 ft.	169999515



No More Tangled Air Hose!

AIR HOSE WHIP

- Designed to reduce stress on fittings and kinking of the air hose
- The 360° male swivel fitting permits the tool to operate at maximum efficiency
- 300 PSI working pressure
- 1,200 PSI burst pressure

Length	Art #
2 ft.	189514151



REPAIR FITTINGS FOR AIR HOSE

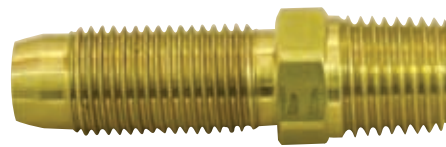

Reusable Hose Ferrule

Size	Art #
5/8" OD to 3/8" ID	1699020002
7/8" OD to 1/2" ID	1699020003

Reusable Male Hose Stem

Size	Art #
3/8" ID to 1/4" MPT	1699021001
1/2" ID to 1/4" MPT	1699021002

Installation instructions:

- Thread the hose ferrule over the end of the hose.
- Thread the hose stem into the hose ferrule.
- * No hose clamps or band clamps are required.

90 PSI REGULATOR

- Attach directly to air tool
- Regulates a constant 90 psi
- Recommended for WURTH DBS 3600 Art. # 07033600 and Sprayable Seam Sealer Gun Art. # 08916284

Description	Art #
90 PSI Regulator	0891161



AIR REGULATOR

- Aluminum body
- 1-1/2" dial gauge 0-160 psi
- Full open to full close with 1/4" turn
- 1/4" FPT inlet, 1/4" MPT outlet
- Will fit all 1/4" air tools
- Use with: DBS 3600 Art. # 07033600, Pneumatic Spray Gun Art. # 0891 6280 & Multi Sprayer Art. # 0891 110
- Made in the USA

Description	Art #
Air Regulator	0891160



SUPER WURTH BLOW GUN

- Developed in cooperation with industrial designers to ensure optimum ergonomics and function
- Ideal for vertical installations
- Noise reduced, meets OSHA
- Maximum working pressure 175 psi
- 1/4" NPY inlet connection



Description	Art #
Super WURTH Blow Gun	07149234

IN-LINE BLOW GUN

- Instant air when sanding, grinding or drilling without having to change tools
- Fits permanently between air hose and coupler
- Small, compact and handy
- Natural angle for easy use
- Durable yet weighs only 2 ozs.
- Precision machinery
- OSHA approved
- Use with 3/8" nipple or male coupler

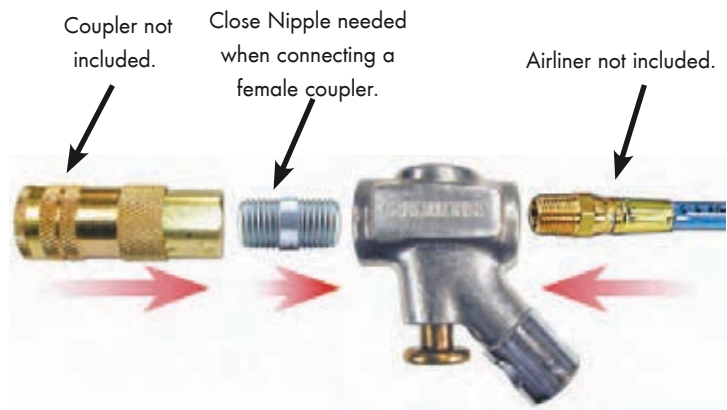

Description	Art #
In-Line Blow Gun	17149227

WURTH PISTOL VAC

Operates wet or dry

Includes:

- Crevice Tube
- Vacuum Bag
- Pistol
- Hose
- Brush
- 20" Extension Tube



Description	Art #
WURTH Pistol Vac	17149227

AIR EVAC II

Features:

- Checks for leaks
- Purges air
- Refills system
- GM recommended

Problem:

- Airlocks in the cooling system of today's vehicles have become a prevalent problem
- The problem can be caused by the positioning of the radiator at a level equal to or lower than the engine
- Upon refilling with liquid, air is trapped in the cooling system reducing circulation
- This results in overheating, added installation time and other problems
- While some OEM's have attempted to address this by installing air-bleed devices on the cooling circuit, they are still plagued by airlocks

Solution:

- The Air Evac II system purges those problematic airlocks, checks for leaks and then allows the technician to refill the system quickly and easily
- Simply connect your shop air to the Air Evac II, pull vacuum, check for leaks and then refill in seconds

Description	Art #
Air Evac II	07145518
Set Includes:	Qty.
Polyethylene storage case	1
Radiator neck adapter with vacuum gauge	1
Refill hose with filter	1
Sold Separately:	Art. #
Air Evac II Fill Hose Assembly	07145520



Description	Art #
Air Evac II Gauge	07145519

Description	Art #
Air Evac II Cone Adapter	07145521

Push Button Couplers	Art #
Yellow Coupler Safety Boot	06997141

SPLIT POINT DRILL



Drill Size	Dec. Equiv. Inches	Flute Length	Overall Length	Art #
3/16"	.1875	2-5/16"	3-1/2"	16283316
13/64"	.2031	2-7/16"	3-5/8"	162831364
17/64"	.2656	2-7/8"	4-1/8"	162831764
9/32"	.2812	2-15/16"	4-1/4"	16283932

National Aerospace Standard 907 Type A, Jobbers Length Drills

- High speed steel, surface treated
- 118° split point
- For use in a wide range of operation conditions
- Bright or Blue

SHEET METAL DRILLS HSS E

- CBN (cubical boron nitride) deep ground
- Universally suitable. Stepless drilling and widening of holes within the diameter range 3-61 mm
- Suitable for drilling of very thin sheet metal
- No countersinking or pre-drilling
- Speed table enclosed
- Burr-free drilling without deforming the sheet metal
- Excellent heat conductivity for improved tool life due to radial and axial relief grinding
- Shank 3 phase ground
- With laser scale, therefore easy indication of required drill hole diameter

Size	Drill Dia. (mm)	Total Length (mm)	Shank Dia. (mm)	Art #
1	3 - 14	58	6	069402414
2	5 - 20	71	8	0694022420



Art. # 069402414 - Tapered: 4-14mm

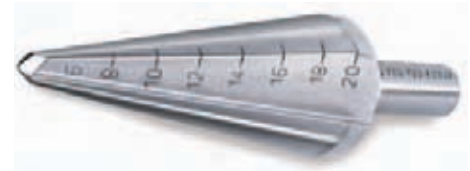

Art. # 069402420 - Tapered: 4-20mm



Speed Table for Stepped Drills

	Material	Non-Ferrous Metals	Stainless Steel Sheets, Nirosa, A2	Plastics, Duroplastics, Thermoplastics	Steel Sheets, Soft, i.e. St14-St37
	Sheet Thickness	0.1 - 6mm	0.1 - 2mm	up to 10mm	0.1 - 4mm
Size	Diameter mm	n=rpm	n=rpm	n=rpm	n=rpm
1	3 - 14.0	2000 - 1500	600 - 400	3000 - 2000	800 - 500
2	4 - 20.0	1500 - 800	400 - 200	2000 - 1500	600 - 300

VARIABLE BIT

- Single cutting edge creates perfectly round holes in metal, wood, plastic and other thin materials
- Constructed of industrial grade high speed molybdenum steel, heat treated and tempered for long life
- 3-sided shank won't slip in drill chuck
- Self-starting tip, no center punch required
- Art. # 0694 14138 cuts 10 different sizes
- Great for drilling car antenna holes

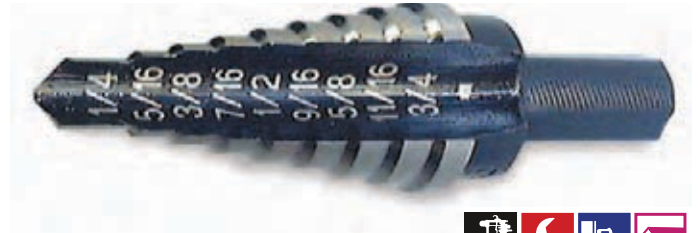

Size	Art #
1/8" - 1/2"	16941812
3/16" - 1/2"	169431612
3/16" - 7/8"	169431678
1/4" - 3/4"	16941434
1/4" - 1-3/8"	169414138

SPOT WELD DRILL BITS

- Special drill bit for the removal of spot welds
- Improved PLUS centering tip is also suitable for high-strength car body sheets
- Suitable for use in any standard drill

Tips to enhance the lifespan of the centering tip:

- Do not use in drills with an impact chuck or spindles
- Set the drill to a suitable speed; the speed of compressed air devices is generally set too high



Type	Size	Total Length (mm)	Groove Length (mm)	Max. Speed	Art #
HSCO	M6	65	28	1,100 rpm	0710006
HSCO	M8	78	38	850 rpm	0710008
HSCO w/ Step	M7.5	Stop 10	88	670 rpm	07100010
HSS	M6	65	28	920 rpm	07106
HSS	M8	78	38	700 rpm	07108
HSS	M10				071010

WELD POINT CUTTER



- Adjustable by actuating adjustment screw
- Cutting crown usable on both sides
- Use in body shops, sheet metal shops, apparatus construction
- No tearing of sheet metal
- No deformation
- Quick and economical

Description	Art #
Weld point cutter	06981
Replacement cutter	069801

METRIC HSS TWIST DRILL BITS



- Type N with cylindrical shank, right hand cut
- For powerful, stable, standard drilling machines, suitable for normal work on conventional materials. For mild and cast steel (alloyed or non-alloyed) grey cast iron, tempered castings, sintered steels, graphite, argentan and nondular iron.

Size (mm)	Length (mm)	Flute (mm)	Art #
1	34	12	062510
1.5	40	18	062515
2	49	24	602520
2.5	57	30	062525
3	61	33	062530
3.5	70	39	062535
4	75	43	062540
5	86	52	062550
6	93	57	062560
6.5	101	63	062565
7	109	69	062570
8	117	75	062580
8.5	117	75	062585
9.5	125	81	062595
10	133	87	0625100



Description	Art #
19 Piece Drill Bit Set	06344

COBALT DRILLS



Drill Size	Dec. Equiv. Inches	Flute Length	Overall Length	Art #
3/6"	.1875	2-5/16"	3-1/2"	16220316 (D176)
3/8"	.3750	3-5/8"	5"	1622038

- Cobalt high speed steel and heat resistant
- Gold finish
- 135° type P3 split point
- For use on stainless steel, titanium high temperature and high strength alloys

TWIST DRILLS



Drill Size	Dec. Equiv. Inches	Flute Length	Overall Length	Art #
1/8"	.1250	1-5/8"	2-3/4"	1624018
7/64"	.1094	1-1/2"	2-5/8"	16240764
9/64"	.1406	1-3/4"	2-7/8"	16240964
5/32"	.1562	2"	3-1/8"	16240532
11/64"	.1719	2-1/8"	3-1/4"	162401164
3/16"	.1875	2-5/16"	3-1/2"	16240316
7/32"	.2188	2-1/2"	3-3/4"	16240732
1/4"	.2500	2-3/4"	4"	1624014
17/64"	.2656	2-7/8"	4-1/8"	162401764
9/32"	.2812	2-15/16"	4-1/4"	16240932
5/16"	.3125	3-3/16"	4-1/2"	16240516
3/8"	.3750	3-5/8"	5"	1624038
1/2"	.5000	4-1/2"	6"	1624012
17/32"	.5312	4-13/16"	6-5/8"	162401732
9/16"	.5625	4-13/16"	6-5/8"	16240916
11/16"	.6875	5-5/8"	7-5/8"	162401116

- 118°
- High speed steel, blue
- For general purpose production drilling
- For use in a wide range of operation conditions
- Used in various materials such as cast iron, steel and steel forgings

Drill Size	Dec. Equiv. Inches	Flute Length	Overall Length	Art #
#7	.2010	2-7/16"	3-5/8"	1624007
#10	.1935	2-7/16"	3-5/8"	16240010
#30	.1285	1-5/8"	2-3/4"	16240030

DRILL BITS

Ultra Bor Super Premium (3 Flats on Shank-3/16" & larger)

Performance Features:

- M7 Industrial Steel withstands high temperatures, maintains sharpness
- 135° Split Point for fast penetration and accurate starting without center punch
- Precision ground point flutes, body, clearance and drill diameter for the ultimate in accuracy and performance
- Black and bronze oxide surface treatments reduce friction
- Especially designed for hand held drills
- 3-flat shank design eliminates slippage and provides a positive grip
- Ideal for drilling in high carbon steel, stainless steel and other hard metal drilling applications

Reduced 3 Flat Shank



Standard 3 Flat Shank

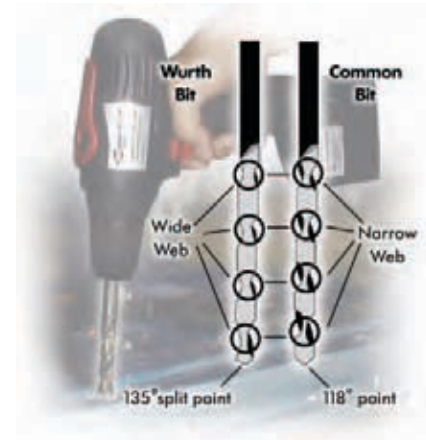

Description	Art #
21 Piece Drill Bit Set	16271100

Description	Art #
29 Piece Drill Bit Set	1627029
Reduced 3 Flat Shank	1627729

Description	Art #
13 Piece Drill Bit Set	16270131

DRILL BITS (CONTINUED)

Diameter Inches	Overall Length	Flute Length	3 Flats Bits Art. #	3/8" Reduced Shank Art. #
1/16"	1-7/8"	7/8"	16270116 ••••	
5/64"	2"	1"	16270564 ••••	
3/32"	2-1/4"	1-1/4"	16270332 ••••	
7/64"	2-3/8"	1-5/16"	16270764 ••••	
1/8"	2-1/2"	1-7/16"	1627018 ••••	
9/64"	2-5/8"	1-9/16"	16270964 ••••	
5/32"	2-3/4"	1-11/16"	16270532 ••••	
11/64"	2-7/8"	1-13/16"	162701164 ••••	
3/16"	3"	1-1/2"	16270316 ••••	
13/64"	3-1/8"	1-5/8"	162701364 ••••	
7/32"	3-1/4"	1-3/4"	16270732 ••••	
15/64"	3-3/8"	1-7/8"	162701564 ••••	
1/4"	3-1/2"	2"	1627014 ••••	
17/64"	3-5/8"	2-1/8"	162701764 ••••	
9/32"	3-3/4"	1-1/4"	16270932 ••••	
19/64"	3-7/8"	1-3/8"	162701964 ••••	
5/16"	4"	2-1/2"	16270516 ••••	
21/64"	4-1/16"	2-9/16"	162702164 ••••	
11/32"	4-1/8"	2-5/8"	162701132 ••••	
23/64"	4-3/16"	2-11/16"	162702364 ••••	
3/8"	4-1/4"	2-11/16"	1627038 ••••	
25/64"	4-5/16"	2-3/4"	162702564 •	
13/32"	4-3/8"	2-13/16"	162701332 •	
27/64"	4-7/16"	2-7/8"	162702764 •	
7/16"	4-1/2"	2-15/16"	16270716 •	
29/64"	4-5/8"	3"	162702964 •	
15/32"	4-3/4"	3-1/8"	162701532 •	
31/64"	4-7/8"	3-1/4"	162703164 •	162773164 •
1/2"	5"	3-3/8"	1627012 •	1627712 •
9/16"	5"	2-3/4"		16277916 •

Color Code	Included in Drill Bit Index	Pcs.
•	16271100	21
•	1627029	29
•	1627729	29
•	16270131	13



HOLESAW ARBORS & PILOT DRILLS

A 1/4" Round Shank

For small holesaws in light weight material and wood.



B 1/4" Shank with 3 Flats

Available for use with 9/16" to 1-3/16" to 2" holesaws. Medium to heavyweight materials.



C 7/16" Hex Shanks

For small holesaws in medium to heavy-weight materials.



D Quick Change 7/16" Hex

Pin drive construction permits fast inter-changing of holesaws.



	Recommended for Holesaw Sizes	Pilot Size	Drill Size	Art #
A	9/16" to 1-3/16"	1/2" - 20	1/4"	1632001
B	9/16" to 1-3/16"	1/2" - 20	1/4"	1632002
C	9/16" to 1-3/16"	1/2" - 20	1/4"	1632004
D	1-1/4" and larger	5/8" - 18	1/4"	1632006

1/4" HIGH SPEED PILOT DRILLS



Use with Above Arbor Size	Recommended for use on	Art #
A,C,D,E	1-1/4" and larger	16320102

Use with Above Arbor Size	Recommended for use on	Art #
B	For general cutting of metal and wood	16320104

HOLESAW ASSORTMENT

- Quick and clean cut thanks to the HSS bi-metal construction
- For use in all steel materials, including cast metal, copper, bronze, aluminum, plastics and wood
- Number of teeth: 6/inch
- Cutting depth: 32 mm

Description	Art #
Holesaw Package 16 Pc.s	0964632

Includes:		
Description	Qty.	Special Order Only Art #
Holder A2	1	063202
Holder A4	1	063204
Hexagon extension, 300 mm	1	063205
Ejector spring	1	063207
D19, D22, D25, D32, D35, D38, D44, D51, D57, D64, D67, D76	1	0632...



HOLESAW TYPES

These hole saws provide an economical means of extending the useful range of portable drills, drill presses and lathes. Made of high speed steel welded to an extremely tough alloy steel back, these hole saws can be used to cut mild steels, cast iron, aluminum, brass and bronze, plastics, iron or steel pipe and wood. Hole saws range in size from 9/16" all the way up to 6" and have a cutting depth of up to 1-1/4". Six teeth per inch allows these hole saws to give you a clean, accurately cut hole.

Red

Used on metal high production tools. Designed for cutting machinable materials, steel, aluminum, copper, brass, sheet metal, stainless steel, wood or plastics.

White*

Used for general construction, plumbing, electrical, maintenance work.

Hole Size	Hole Saw Adapt. #	Pipe Tap	Pipe Entrance	Copper Pipe Size I.D.	Art #
5/8"	-	-	-	1/4"	163258
3/4"	-	-	3/8"	1/2"	163234
7/8"	1632002	3/4"	1/2"	5/8"	163278
1"	-	-	-	3/4"	16321
1-1/8"	-	-	3/4"	3/4"	1632118
1-1/4"	-	-	-	1"	1632114
1-3/8"	-	-	-	-	1632138
1-1/2"	-	-	-	1-1/4"	1632112
1-3/4"	1632008	-	1-1/4"	1-1/2"	1632134
2"	-	-	1-1/2"	-	16322
2-1/4"	-	2"	-	2"	1632214
2-1/2"	-	-	2"	2"	1632212
3"	-	-	2-1/2"	2-1/2"	16323
4"	-	-	-	-	16324



STUB LENGTH DRILLS

- 180° below 1/16" & above 1/2"
- 135° below 1/16" - 1/2"
- High speed steel, blue
- For general purpose production drilling
- For use in a wide range of operation conditions
- Used in various materials such as cast iron, steel and steel forgings

A230				
Drill Size	Dec. Equiv. Inches	Flute Length	Overall Length	Art #
1/8"	.1250	7/8"	1-7/8"	1635018
1/4"	.2500	1-3/8"	2-1/2"	1635014

A120				
Drill Size	Dec. Equiv. Inches	Flute Length	Overall Length	Art #
5/16"	.3125	1-5/8"	2-13/16"	16350516
3/8"	.3750	1-13/16"	3-1/8"	1635038

TWIST DRILLS - WIRE GAUGE SIZES

118° Above Gauge 42				
Drill Size	Dec. Equiv. Inches	Flute Length	Overall Length	Art #
#11	.1910	1-3/16"	2-1/4"	1635111

135° Gauge 42 and Below				
Drill Size	Dec. Equiv. Inches	Flute Length	Overall Length	Art #
#29	.1360	15/16"	1-15/16"	1635129
#30	.1285	15/16"	1-15/16"	1635130

TWIST DRILLS - LEFT HANDED DRILL BITS

Size	Length	Art #
1/8"	2-3/4"	0625715
3/16"	3-1/2"	0625316
1/4"	4"	0625714
5/16"	4-1/2"	06255116
3/8"	5"	0625318



TWIST DRILLS - HIGH SPIRAL CAR STYLE REAMER

- 1/2" Diameter shanks
- Heavy duty steel
- Designed for truing, aligning and deburring holes in structural steel members, automotive maintenance and fabrication
- Useful in cramped quarters with any 1/2" 3 jaw power tool
- Used for various type of metals including mild and surface hardened steel, 4140 steel, cast iron and steel
- Built in collar prevents over penetration
- The left hand fast spiral right hand cut is developed for high speed



Drill Size	Dec. Equiv. Inches	Flute Length	Overall Length	Recomm. Pilot Hole	Qty.	Package Art. #
1/2"	.5000	3-5/8"	5-15/16"	5/16"	1	1698012
5/8"	.6250	4-1/4"	6-9/16"	5/16"	1	1698058
3/4"	.7500	4-9/16"	7"	1/2"	1	1698034

HSS DRILL BITS DOUBLE-ENDED

- WURTH HSS Double-Ended Drill Bits are a special purpose drill bit that facilitates penetration of the drill into the material
- No center punching is required and the drill does not drift from the drilling location
- Ideal for machining of thin materials and for drilling rivet holes



Size		Length	Shank	Art. #
mm	inches			
3.0		56 mm	10.6 mm	063630
3.1		60 mm	11.2 mm	063631
3.2	1/8"	60 mm	11.2 mm	063632
5.0	13/64"	79 mm	17.0 mm	063650
6.2	1/4"	91 mm	21.2 mm	063662

BIT HOLDERS - HEX SHANK HOLDER

Magnetic	
Description	Art #
1/4" Hex Shank Holder x 2-31/32" for 1/4" Bits	1614324902
1/4" Hex Shank Holder x 2-31/32" for 5/16" Bits	1614324981

BIT ADAPTERS - MALE

Non-Magnetic	
Description	Art #
Adapter 1/4" Male Hex Drive to 3/8" Male Square Drive 1-5/8" OAL	1614363008

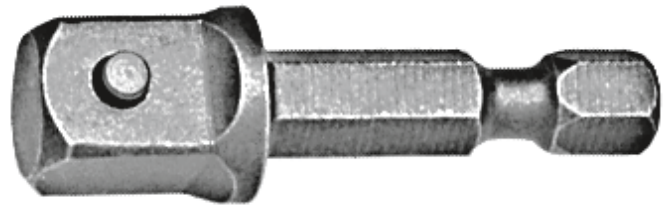
BIT HOLDERS - NUTSETS

Magnetic		
Description	Length	Art #
Nutsets 1/4" Dia. Short	1-3/4"	06149175
Nutsets 1/4" Dia. Long	6"	06149176
Nutsets 5/16" Dia. Short	1-3/4"	1614359010
Nutsets 5/16" Dia. Long	6"	06149178
Nutsets 3/8" Dia. Short	1-3/4"	06149179

BIT ADAPTERS - FEMALE

Non-Magnetic	
Description	Art #
Adapter 1/2" Female Square Drive for 1/4" Hex Inserts 1-3/4" OAL	1614328581
Adapter 1/2" Female Square Drive for 5/16" Hex Inserts 1-3/4" OAL	1614328551



BIT HOLDERS - QUICK CHANGE BIT HOLDER
Non-Magnetic

Description	Art #
1/4" Quick Change Bit Holder	0614176711

BIT ADAPTERS - 1/4" HEX SHANK BIT HOLDER FOR 5/16" INSERTS
Magnetic

Overall Length	Ref. #	Art #
3-1/16"	M498	1614324981

SCREW DRIVER BITS - PHILLIPS

Hex	Tip	Length	Art #	
1/4"	#1	1"	0614176274	
	#2		0614176461	
	#3		0614176648	
	#2	1-5/16"	1614324922	
	#3		1614334931	
	#1	2"	0614176735	
	#2		0614176736	
	#3		0614176737	
	5/16"	#2	2-3/4"	1614334922
		#2	6"	1614314921
#3		1-1/4"	1614214002	
			1614214003	

SCREW DRIVER BITS - POZDRIV

Hex	Tip	Length	Art #
1/4"	#2	1"	0614176652
	#3		0614176653



SCREW DRIVER BITS - POZDRIV

Hex	Tip	Length	Art #
1/4"	1/32"x7/32"	1"	0614175653

SCREW DRIVER BITS - TORX

Hex	Tip	Length	Art #
1/4"	T-10	1"	06143110
	T-15		06143115
	T-20		06143120
	T-25		06143125
	T-27		06143127
	T-30		06143130
	T-40		06143140
5/16"	T-30	1-1/4"	1614514030
	T-40		1614514040
	T-45		1614514045
	T-55		1614514055

SCREW DRIVER BITS - SQUARE DRIVE RECESS

Hex	Tip	Length	Art #
1/4"	#2	1"	161420002

SCREW DRIVER BITS - HEX BIT

Shank	Hex Size	Length	Art #
1/4"	3	1"	061417693
	4		061417694
	5		061417695
	6		061417696



SCREW DRIVER BITS - 5/16" HEX SHANK INSERT TORX DRIVE

Driver Size	Overall Length	"A" Ref #	Art #
T-30	1-1/4"	.216	1614514030
T-40		.260	1614514040
T-45		.107	1614514045
T-50		.128	1614514050
T-55		.151	1614514055

SCREW DRIVER BITS - 1/4" HEX SHANK "EXTRA LONG" PHILLIPS DRIVE

Point Size	Overall Length	Art #
2	2-3/4"	1614334922

SCREW DRIVER BITS - 1/4" HEX SHANK "JUMBO LENGTH" PHILLIPS DRIVE

Point Size	Overall Length	Art #
2	6"	1614314921

SCREW DRIVER BITS - 5/16" HEX SHANK INSERT PHILLIPS DRIVE

Point Size	Overall Length	Art #
2	1-1/4"	1614214002
3		1614214003

SCREW DRIVER BITS - 1/4" HEX SHANK "LONG" PHILLIPS DRIVE

Point Size	Overall Length	Art #
2	1-5/16"	1614324922
3		1614334931



ZEBRA SAW FRAME



- With two-component plastic handle. Secure grip, fatigue-free working
- Two saw blade positions. (45° and 90°) One features flush cutting
- Tensioning crank. Integrated in handle
- Handle slopes toward the rear. Starting edge remains unrestricted
- Saw blade tensioning to 176 lb. with slack-adjustment system
- Length: 15-3/8"
- Complete with one HHS 24 teeth bi-metal saw blade

Description	Length in mm	Art #
Zebra Saw Frame	390	071464015

ZEBRA HSS HACKSAW BLADES



No saw blade offers higher cutting capacity and flexibility.

- Special steels; high alloy high speed steel at the toothed edge, tough tool steel for the back
- Most up-to-date manufacturing techniques guarantee unexcelled quality and precision. For example, Electron beams are used to weld joints.
- The toothed edges are made of fully hardened steel so their cutting capacities and service lives are unsurpassable
- You work with one saw blade more quickly, longer and thus more economically

Application

- Tool steel (high and low-alloyed)
- Structural steel (high and low-alloyed)
- High-speed steel
- Stainless steel

Normal toothting

- Very economical
- Increased safety
- High cutting performance
- Longer service life

* Progressive toothting

Clear advantages due to different tooth pitches.

- For universal use
- High tooth pitch in area of start of cut enables easy start of sawing. "Fluttering" of thin materials is considerably reduced.
- Low tooth pitch in remaining cutting area enables high cutting performance

Material Thickness in mm	# of teeth on 1"	Length in mm	Width in mm	Thick. in mm	Art #
Over 2	24	300	12.5	0.63	060330013
Up to 2	32				0603300133
	18-32		13.0	0.65	060330113*

WURTH SAWZALL BLADES

- Reduces the risk of breakage and achieves 2-10 times the service life compared with plain HSS blades
- High resistance to heat due to high speed steel containing 8% cobalt at the cutting edge
- Highly flexible, unbreakable combination of HSS and HCS metals
- Blade width is 3/4"
- Cooling improves saw life of blade - we recommend using Cutting Oil Art. # 089305004



Type	Length	Teeth/ inch	Art #
waved, milled	4"	24	0615910010
teeth set, milled		18	0615910014
waved, milled	6"	24	0615915010
teeth set, milled		18	0615915014
teeth set, milled		14	0615915018
teeth set, milled		8-14	0615915026
teeth set, milled	12"	10-14	0615930526
teeth set, milled	9"	6	0615722842
teeth set, milled	8"	14	0615920318
teeth set, milled	8"	10-14	0615920326

ULTRAFLEX - BLUE TIP

Standard Steel / Low Tungsten Alloy

Hand hacksawing is an efficient method of separating metal on small and medium jobs that cannot be cut on a machine. Be sure to select the proper blade that will give you the best results.

The finest quality "standard" steel blade available which will perform as well as many HSS blades because of the considerable tungsten content. Ideal for softer materials. Excellent for schools, etc. where cost efficiency is necessary.



Length	Teeth per Inch	Art #
12"	24	1603305224

SET OF WARDING FILES

- With wooden handles
- In plastic case
- 6 piece set, DIN 7283

Type	Length in mm	Cut	Qty.	Art #
flat	100	2	1	07146174
flat pointed				
half round				
round				
triangular				
square				

CALIPER FILE

- For removal of brake dust, rust and dirt from the caliper housing
- Helical gear on one side
- Plastic handle
- 150mm blade length, 10mm wide, 5mm thick & 260mm total length

Length mm	Total length mm	width x thickness mm	Qty.	Art #
150	260	10 x 5	1	07146179

CHEESEGRATER ROUND FILE

- Shape plastic fillers, wood & metal, fast and easy
- Smooth cutting
- Non-clogging
- Extra sharp

Description	Art #
Cheesegrater Round File	158596

FILE BOARD SANDER

- For dry abrasive paper
- For quicker flat sanding of polyester filler, flat surfaces and joints
- Plastic handle

Description	Art #
File board sander	0586445

BODY FILE HANDLE

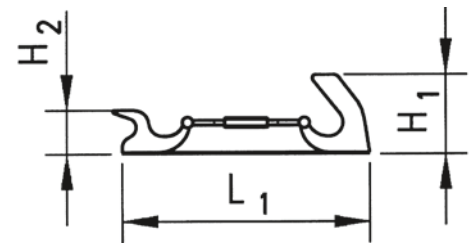

- Concave and convex adjustable
- Handle made of aluminum



For Blade Width mm	Length L1 mm	Height H1 mm	Height H2 mm	Qty.	Art #
35	350	110	60	1	07146173

BODY FILE BLADES

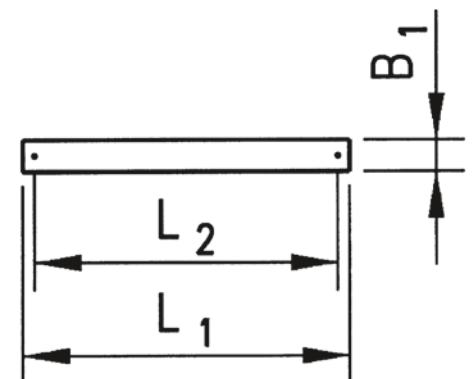
- Radially milled on both sides
- Suitable for Art. # 07146173



Type	Teeth per inch	Length L1 mm	Hole distance L2 mm	Width B1 mm	Qty.	Art #
Radial medium	12	350	325	35	1	07146172

MICROBRUSH™

- Comprised of small non-linting, non-absorbent fibers
- Solutions applied are held in suspension between fibers creating a non-dripping sphere which contains the material until it is applied
- Exact placement of solutions as small as 1/8 of a drop can be accurately applied
- Bends easily into any angle for the placement of material in areas of limited access
- Disposable - savings up to 60% are possible by the reduction of excess required by ordinary bristle brushes



Description	Art #
Microbrush™	1693300

BRAKE CALIPER BRUSH

- For easy removal of caked on brake dust
- Thin profile allows for easier cleaning in confined areas
- 1-1/2" wide, 8-3/4" long and 3/8" thick



Description	Art #
Brake Caliper Brush	07155526

SMALL WIRE BRUSHES

- Overall length is 7-1/4"
- Poly handle
- Multi purpose brush



Description	Art #
Stainless Steel	17146993
Brass	17146994

SPARK PLUG BRUSH

- With wooden handle and wavy brass wire bristles
- Use to clean electrodes and contacts of spark plugs



Description	Art #
Spark Plug Brush	07155158

ACID BRUSHES

- Heavy duty stainless steel handle
- Excellent for spreading Seam Sealers
- Horse hair bristles

Description	Art #
3/8" wide x 6" long	06933020
1/2" wide x 6" long	06933021



SPOT SANDING PEN



Clean rust, wax or dirt from any tight corner, crevice or hard to reach spot. It's like a pencil point sandblaster!

Features:

- Paint repairs are better looking and permanent
- Gets in where other tools can't reach
- The glass fibers are finer than human hair yet stronger than steel when it comes to cleaning power
- The cartridge can be extended out (by turning) as needed, then easily retracted when not in use
- Amply sized body makes it easy to hold for a comfortable grip
- Comes with one refill in handle

Applications:

- Remove rust from dings
- De-rust chrome and precision tools
- Clean electrical contacts and cable ends
- Clean recessed patterns
- De-gloss parts before gluing

Description	Art #
Spot Sanding Pen	158501

1" DISPOSABLE BRUSH

- Perfect for applying Rust Guard and Bedliner & Industrial Coating, as well as many other uses

Description	Art #
1" Disposable Brush	189091804



KNIVES

- Red plastic handle
- One touch slider
- Replaceable blade
- Razor tip can be renewed by breaking off the old tip exposing a new sharp edge

Description	Art #
Heavy Duty Knife	17156610
Replacement Blades	17156611
Standard Duty Knife	07156604
Stainless Steel Pocket Knife	171566061
Replacement Blades	07156607



WURTH UTILITY KNIFE

- Fits all standard utility blades
- Easy to locate in any tool box or pouch, at the job-site or shop
- Professional quality
- Safety overlap design
- Handle: aluminum diecast, painted
- Lock: adjustable to one of several levels
- Blade can be fully retracted
- Closure: screw closure
- Includes 1 heavy duty blade



Description	Art #
WURTH Utility Knife	07156601
Replacement Blades	07156605

RAZOR BLADES

- Strong steel back, single edge
- Individually wrapped for rust and edge protection
- Both styles 100 per box

Description	Art #
Grade 9 Standard Duty .009"	16033010
Grade 12 Heavy Duty .012"	16033009



PLASTIC RAZOR BLADES

- Easy to remove stickers from windshield without risk of cutting or scratching windshield
- Ideal for scraping many surfaces in automotive, industrial or home applications
- Made of polypropylene

Description	Art #
Plastic Razor Blades	16033011



UTILITY BLADES

- The new generation of safety blades! Unbreakable under normal working conditions.
- 3x higher service life than standard blades
- Pliable and flexible. If necessary, the blade can be bent and worked with accordingly.
- Use with retractable utility knives

Description	Art #
5 pack w/safety dispenser box	07156602
25 pack bulk - NO dispenser box	1695106

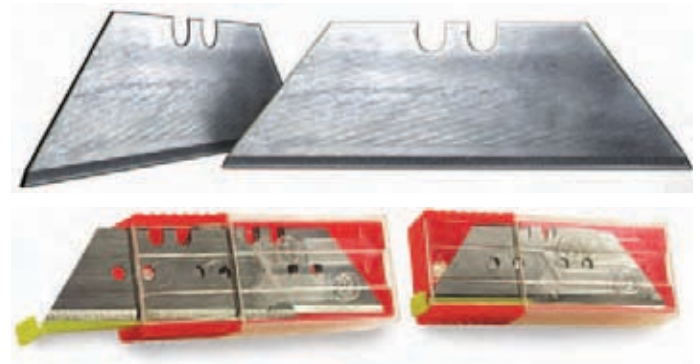

CARTRIDGE TIP CUTTER

- Cuts the perfect angle on all plastic cartridge tips
- Cuts straight edge on our threaded sprayable seam sealer cartridges

Description	Art #
Cartridge Tip Cutter	07156609



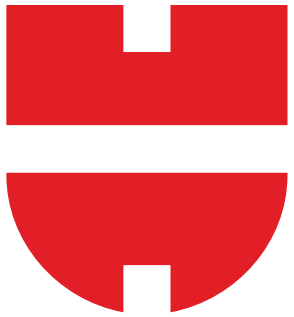

WÜRTH

WURTH COMBINATION SHEARS

- For right & left hand cutting
- Stainless steel blades
- Lightweight

Description	Art #
WURTH Combination Shears	07140314



HOG RING PLIERS

- Straight nose grip
- Holds rings in place for fast work

Description	Art #
Hog Ring Pliers	150150001



RAZOR SNIPS

- Replaceable razor sharp steel blade
- Large jaw opening
- Wide flat anvil provides solid cutting surface
- Includes inch & centimeter scale
- Non-marring surface protection
- Convenient handle storage includes 5 replacement blades
- Steel frame with rubber grips

Description	Art #
Razor Snips	171431610
Replacement blades (6 pcs.)	171431612



INSULATED & NON-INSULATED CRIMPING PLIERS



- Cutting of screws M2.6-M5 diameter.
- Cutting of wires and stripping of insulation 20-8 gauge
- Crimping of insulated and non-insulated cable connectors

Description	Art #
Insulated & Non-Insulated Crimping Pliers	055810

INSULATED CRIMPING PLIERS



- Cutting of screws M2.6-M5 diameter
- Cutting of wires and stripping of insulation 20-8 gauge
- Crimping of insulated cable connectors

Description	Art #
Insulated Crimping Pliers	055811

NON-INSULATED CRIMPING PLIERS



- Cutting of screws M2.6-M5 diameter
- Cutting of wires and stripping of insulation 20-8 gauge
- Crimping of non-insulated cable connectors

Description	Art #
Non- Insulated Crimping Pliers	055813

INSULATED & NON-INSULATED CRIMP TOOL



- Crimping tool for crimping of insulated cable connectors
- Positive locking action guarantees quality crimping result
- Prevents faulty crimping results
- Power boost owing to transmission lever
- Low force requirement, comfortable handling
- Three crimping stations: 22-18, 16-14, 12-10

Description	Art #
Non- Insulated Crimp Tool	05581109

WIRE STRIPPER



- Easy one hand operation
- Ergonomically designed
- Hardened steel blade
- Strips and removes excess wire in one squeeze
- Strips up to 10 gauge (6 mm) wire
- Ideal for working in confined areas
- Made in Germany
- Full WURTH one year warranty

Description	Art #
Wire Stripper	0691500

COMPACT CRIMPING TOOL HAMMER TYPE

- Crimping tool driven by hammer impact with locking lever for easy loading
- Crimps terminals 8 to 4/0 gauge

Description	Art #
Compact Crimping Tool Hammer Type	171599840



VEHICLE TEST LAMP

- Brass construction
- 6 to 24 volts
- Wire length 30"
- Chrome vanadium tip with protective screw-on cap

Description	Art #
Vehicle Test Lamp	069500224

SHARP SHOOTER

Sharp Shooter sprayers are an inexpensive way to apply bulk chemicals like cleaners, degreasers, penetrating oils, solvents and lubricants. They use readily available compressed air, instead of flammable or dangerous propellants, and because they are reusable you don't have to worry about disposal of empty cans.

- 32 oz. capacity
- Adjustable nozzle
- Ideal for use with Wurth Brake Cleaner, Rost Off & more
- Fully automatic
- Rugged all metal welded construction
- Air pressurized, uses a standard air chuck
- Refillable & reusable
- Adjustable nozzle allows adjustment from pin steam to an extra fine mist
- Great for Low VOC and Zero VOC Brake Cleaner
- Do not use water or water-based materials in steel sprayers
- Not recommended for paint



Description	Art #
Sharp Shooter	08911102
Rebuild Kit	089111021
Refill Pot, 1 quart	089111022
Replacement Nozzle	089111023
Air Chuck Refiller Cap	089111024
Flexible Wand	089111025



QUICK SHOOTER

- 16 oz. capacity
- Hand held, no trailing hose or cord
- Works from 80 PSI to 150 PSI, maximum pressure 200 PSI
- NOT recommended for Throttle Body Cleaner

Description	Art #
Quick Shooter	08911200
Replacement Nozzle	08911201
Rebuild Kit	08911202
Nozzle w/ Straws	08911204



ROST OFF PUMP BOTTLE

- 1 liter

Description	Art #
Pump Nozzle	0891503
Nozzle	08915990
Replacement O-Ring	0891599
Rost Off Twp for 5 gal. Container	089130201



ALL PURPOSE GERMAN SPRAY PUMP

- Ideal for most chemicals
- 1 Liter capacity
- Area for labeling your product
- Unique pump design
- Not intended for Low VOC Brake Cleaner

Description	Art #
All Purpose German Spray Pump	0891501



BRAKE CLEANER PUMP BOTTLE

- 1 liter
- Not intended for Low VOC Brake Cleaner

Description	Art #
Pump Bottle	089150108
Nozzle	08915990
Replacement O-Ring	0891599



CHEMICAL RESISTANT SPRAY BOTTLE

The bottle is made of a thicker resin which offers greater durability and longevity. This sprayer now offers compatibility with an even wider range of chemicals. The bottle graphics include a check off grid for identifying contents and a handy graduation scale for diluting liquids.

- Output: 3.0 cc per stroke
- Constructed with chemically resistant materials
- Fully adjustable spray pattern
- 32 oz. capacity
- 3 imprinted measuring scales (oz. c.c., dilution)
- Built-in strainer to prevent particle clogging

Note: No sprayer is compatible with all chemicals, and no sprayer should be used with chlorinated solvents (including bleach) or chemicals that harden and congeal.

Description	Art #
Chemical Resistant Spray Bottle	0891504



GENERAL PURPOSE SPRAY BOTTLE

- 24 oz. capacity
- A longer trigger gives more comfortable balanced grip, providing a longer, steadier use duration
- Each stroke produces over 40% more output than standard spray heads

Description	Art #
General Purpose Spray Bottle	08915010



PUMP DISPENSER

- Fits 5 gallon containers

Description	Art #
Pump Dispenser	089100103



UNIVERSAL POUR SPOUT

- Fits 1 quart & 1 gallon containers

Description	Art #
Universal Pour Spout	089191071



WURTH OIL EXTRACTOR KIT

- Ideal for changing oil on tractors, cars, motorcycles, boats and many other types of engines
- Suitable for removing various types of fluids, such as hydraulic oil, cutting oil and engine oil
- Made of impact-resistant materials and extremely corrosion resistant
- Ideal for degreasing and cleaning even where aggressive chemicals are used
- Shipped with 2 liter container
- Maximum working pressure 87 to 174 psi
- 1/4" inlet connection

Description	Art #
WURTH Oil Extractor Kit	07145525



SPRAY MASTER

- Fits European aerosol cans

Description	Art #
Spray Master	0891090



GENERAL PURPOSE LEVER BARREL PUMP

Ideal for:

- Water, Alcohol, Gas, Diesel, Kerosene & Petroleum Based Products

Fits:

- 35 to 53 Gallons Drums

Construction:

- Polypropylene Housing, Steel Rod, Viton® Seals

Delivers:

- 9 oz. / Stroke

Description	Art #
General Purpose Lever Barrel Pump	189100105



OILER

- Constructed from transparent plastic
- Retractable shaft
- Adjustable nozzle to regulate flow
- 8 oz. capacity

Description	Art #
Oiler	069555323



FAUCET FOR 35 GALLON BRAKE CLEANER

- Self closing faucet fits all drums and barrels with a 3/4" bunghole
- Ideal for lacquer

Description	Art #
Faucet for 35 gal. Brake Cleaner	189100104



SINGLE STATION DISPENSER/MIXER

Single station modular dispensing system that can be ganged together and made up from a combination of 1 and 4 gallon per minute units. Versatile dispenser allows user to build the system they require or mount units individually. Mixes/blends concentrated chemical product with water to the desired dilution ratio. Specify 1 or 4 gallon per minute.

- Perfect for concentrated Bulk Eco Products
- Push button activator
- Convenient stickers to identify product
- Can be used with most concentrated chemicals
- Easy to install and mount
- 8 1/2 foot long pick up hose

Description	Art #
Single Station Dispenser/Mixer	1895633427



CARTRIDGE GREASE GUN

- Twin-lock system prevents dummy lubrication and grease leakage at piston
- Includes metal pipe and rubber hose
- Use only in accordance with instructions
- Suitable for Art. # 0890 402

Instructions:

1. Unscrew gun head
2. Draw back handle
3. Remove both grease cartridge (max. 400g/14 oz.) covers and insert in gun
4. For bulk grease (max. 500g/16 oz.) draw back handle 5cm/2", fill and repeat
5. Screw on gun head
6. Press clamping lever
7. Push plunger rod into gun
8. Open valve

Description	Art #
Grease Gun	098600
Hose	0986002
End Piece	0986003

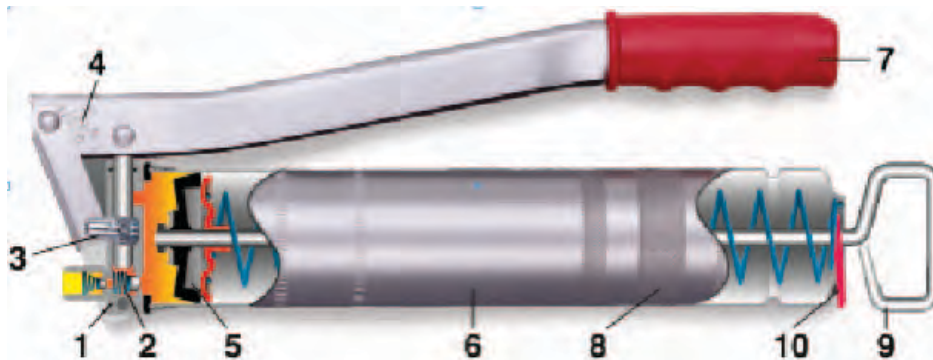

1. Precision steel pump mechanism, no false lubrication, no wearing seals.
2. Short-stroke feed system, grease feed possible at any opening angle, two inlet openings, good grease flow even at low temperatures.
3. Filling and bleeding valve. Filling possible with cartridges, loose grease and with filling unit.
4. Dosing scale for controlled grease outflow.
5. Grease and oil-resistant special sealing piston.
6. Rugged precision pipe.
7. Ergonomically shaped safety handle.
8. Anti-slip knurled marking in handle area.
9. Closed piston-rod handle.
10. Locking system - stepless, anti-slip piston rod locking - no accidental triggering!

Design complies with German standard DIN 1283 (M10x1) and is TÜV/GS, BLT and DLG-tested.

PISTOL TYPE GREASE GUN

- Heavy duty grease gun for one hand operation
- 2-way loading, cartridge or bulk load
- Equiped with 3-1/2" grease pipe and coupler
- Zinc die cast head assembly, heavy gauge barrel with slip resistant painted cover
- Pistol grip parts are zinc plated
- Plunger shaped for three way loading
- Plunger rod with Posi-Lok feature
- 4 jaw hydraulic coupler
- Develops up to 5,000 PSI
- With 12" flexible hose
- Maximum 400g/14 oz



Description	Art #
Grease Gun	19869010
Coupler	19869003
Hose (sold separately)	0986002

MANUAL CARTRIDGE GUN



- For dispensing 150, 225 & 300 ml. cartridges

Description	Art #
Manual Dual Cartridge Gun	08910091

MANUAL 200 ML. CAULK GUN, 2:1 RATIO



- 200 ml.
- Mechanical Advantage 26:1
- Side Loading Frame - Accurate Cartridge Placement
- For use with 2:1

Description	Art #
Manual 200 ml. Caulk Gun	08910200

MANUAL DUAL 50 ML. CARTRIDGE GUN



- For dispensing our Wurthfix All Art. # 0893 301900 and any 50 ml. cartridges
- Heavy duty construction

Description	Art #
Manual 50 ml. Cartridge Gun	1891989348

PNEUMATIC DUAL CARTRIDGE GUN



- True air regulator, 100 PSI maximum
- Dump valve stops material flow
- Adjustment knob controls flow
- Nominal thrust 484 lbs.
- For dispensing 150, 225 & 300 ml. cartridges
- Adjustable plungers to dispense 2:1 ratio cartridges

Description	Art #
Pneumatic Dial Cartridge Gun	08910092





ADAPTER FOR WURTH FIXALL

- Use with single cartridge style guns

Description	Art #
Adapter for WURTH FixAll	08910004





MIXER TIPS

Type	Description	Art #
	Mixer Tip for Powerbond	08919609
	Large Mixer Tip 10 oz. Cartridge for 7 & 10 oz.	08910014
	Small Mixer Tip Cartridge for 7 & 10 oz.	08910013
	Large Mixer Tip for 50 ml.	089191060
	Small Mixer Tip for 50 ml.	08910005

CAULKING TIPS

- Screws onto Wurth 310 ml. cartridges
- Wide tip produces a "flat" bead of Seam Sealer to any width desired
- Markings on wide flat bead tip are easy to read so tech can cut to desired width
- Wide tip is ideal for P/U beads and door skins

Type	Description	Art #
	AdhesiveFlex Tip	089165320
	Wide Flat Bead Tip	0891660
	Standard Round Tip (Will not fit AdhesivFlex)	0891653

SINGLE CARTRIDGE AIR CAULKING GUN



- Permits smooth flow caulking
- Works with all single cartridge Seam Sealers including AdhesivFlex

Description	Art #
Single Cartridge Air Caulking Gun	1891010

DELUXE CAULKING GUN



- Heavy duty
- One touch shut-off eliminates product dripping
- The finest hand operated Caulking Gun in the world
- Center balanced
- Cartridge holder removable for easy cleaning
- For use with 310 ml. cartridges

Description	Art #
Deluxe Caulking Gun	089100

NO DRIP CAULKING GUN



- For use with 310 ml. cartridges
- Automatic vacuum action prevents dripping
- Heavy gauge metal
- Variable power settings
- Reduces clean up time
- Built in spout cutter
- Built in ladder hook
- Built in top piercer

Description	Art #
No Drip Caulking Gun	0891000

SAUSAGE PACK GUNS



Description	Art #
300 ml./13.53 oz.	0891300300
Bead Nozzle Tip	0890100206



Description	Art #
600 ml./20.29 oz.	0891400600
Replacement Nozzle Tip	0890100600

UBS SPRAY GUN

- For fast application of stone-chip and underbody protection products on a plastic, bitumen and wax basis
- With variable spray nozzle for restoring original structure on sill panels, wheel wells, floor groups, etc.
- R 1/4" connection
- Only gun needed for both water and oil-based SKS , underbody seal and body wax

Description	Art #
UBS Spray Gun	08911063



SCHUTZ GUN (USA THREAD)

- For Bedliner Kit Only

Description	Art #
Schutz Gun	0891106233



SPRAY GUN (WITH 1 QT. ALUMINUM CUP - 1.7MM NOZZLE)

- All-purpose easy-to-clean paint spray gun
- Two-piece construction with gun featuring exclusive air valve design
- Fully adjustable wide fan pattern control
- 1 quart (946cc) capacity dripless cup
- **Perfect for use with WURTH Shield**

Specifications:

Nozzle Size:	1.8mm
Operation Pressure:	50-65psi
Net Weight: 2.31lbs. (1.05kg)	
Dimensions W x H:	7"x12"
Avg. Air Consumpt.:	7-12cfm
Air Inlet Thread NPT:	1/4"
Required Compressor:	3hp
Max. Pattern at 8" Distance: (280mm)	11"
Fluid Inlet Thread NPT:	3/8"
Air Hose I.D. Size:	6-8mm



Description	Art #
Spray Gun	189170010

MULTI SPRAYER

The WURTH Multi Sprayer can spray SKS, Body Wax/Rust proofing, Underbody Seal or any petroleum or water based products.

- WURTH Multi Sprayer can duplicate any OEM texture of chip guard or undercoat.
- Three adjustment knobs allow infinite spray patterns
- The WURTH Multi Sprayer is classified as an H.V.L.P. (High Viscous Low Pressure). This allows thicker than normal products to be sprayed at low pressures with the advantage of very little over spray.

Description	Art #
Multi Sprayer Set	0891110
Spray Mist Wand	08911511
90° Wand	08911510



PNEUMATIC SEAM SEALER GUN

- Very little maintenance.
- Duplicates original OEM sprayed textures.
- Use care when screwing cartridge into gun.
- Always leave a cartridge in the gun.
- A great time saver when repairing large areas such as in or around the trunk or fender wells.
- Special bead nozzles included.

Description	Art #
Seam Sealer Gun	08916284
Round Bead Tip	0891165320
Flat Bead Tip	0891660

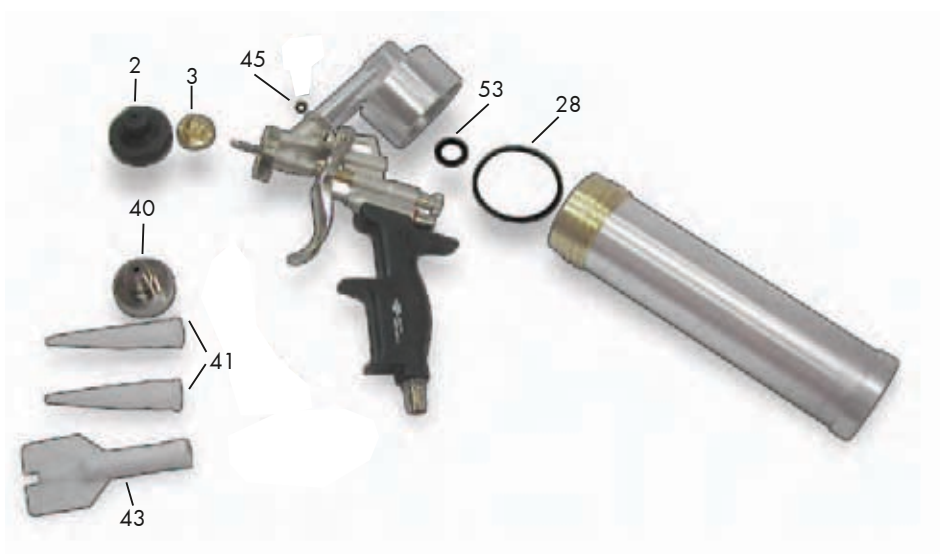

Pic. #	Description	Art #
#2	Spray Cap	18916289
#3	Nozzle	18916290
#28	Canister O-Ring	18916291
#40	Extrusion Cap	18916292
#41	Bead Tip	089165320
#43	Wide Flat Bead Tip	0891660
#45	Air Regulator O-Ring	18916293
#53	Cartridge O-Ring	18916294

MICRO GRIP

Small grip pliers with toggle point joint clamping system.

Features

- Adjustable toggle joint clamp, jaw width 0-12mm, always guarantees the highest clamping force in extremely small space.
- Compact design (overall length 92mm) and low weight of 120g is handy, practical and universally useable.
- Advantage through use of high strength aluminum for easy handling, resistant against welding splashes, suitable for aluminum repairs.

Description	Art #
Micro Grip	07140932

Easy to use...

Adjust

Clamp

Release

WELDING CLAMPS

For quick and easy fixing of sheet metal for welding or bonding.

WURTH Patented Product

Features

- Quick fastening and loosening clamps for enormous time savings in comparison to impact or screw clamps.
- Most economical alternative to conventional vise grip pliers.
- Large clamping range in comparison to clamp size, owing to their small size (corresponding to a door seal); gap dimensions can be set without effort.
- No cumbersome loosening or opening of clamps.
- Readjustment of sheet metal possible at any time without problem.
- The special angled shape of the pliers allow universal use of the clamps.
- Use clamps in tight spaces, such as: Trunk edges, hatchback, door columns, triangular windows, etc.

Description	Art #
Welding Clamp Set	096574417

Includes			
Description	Sheet Metal Thickness	Pack Qty	Art #
8 Welding Clamps - Zinc	0 - 2.5 mm	5 pcs	0713744025
8 Welding Clamps - Yellow	2.5 mm - 5 mm	5 pcs	0713744050
Welding Pliers	0 - 2.5 mm		071374401

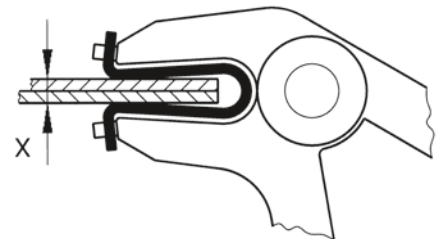
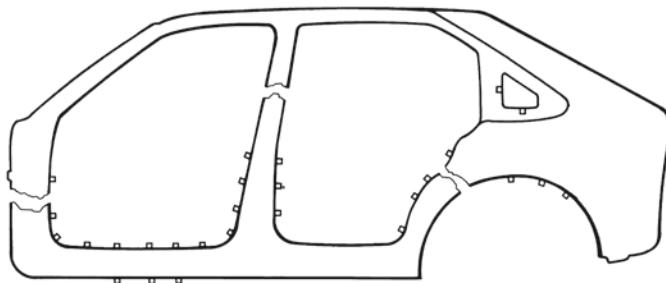
3 Easy Steps

1. Insert the welding clamp into the welding pliers and open the clamp.

2. Slide the clamp over the sheet metal edges to be joined and release the pliers.

3. The powerful force of the welding clamp keeps the clamped sheet metal in place. To remove the fixing clamp, slide the pliers over the clamp and open.

HIGH TEMPERATURE PROTECTIVE BLANKET HTD 1000

To protect sensitive components during welding and soldering work.

- Suitable for use under extreme conditions
- Can be used for soldering work on piping
- Resistant to sparks, slag, welding beads and red hot materials
- Asbestos-free
- Resists temperatures up to 1,562 ° F, up to 1,832 ° F for short periods of time

Size	Art #
13" x 20"	09843501
40" x 60"	0984350



BIONIC SHIELD

- Extended top-of-head coverage
- Superior optics and full face visor designed to maximize visibility and protection
- Suggested for applications requiring dielectric protective equipment
- Built-in chin protection deflects flying particles and debris
- Adjustable head size with a simple turn switch
- Suitable for grinding and sanding

Description	Art #
Bionic Shield	0984660
Replacement Visor	0984661



PICK HAMMER



- Chip away unwanted weld splatter and slag as well as scale, rust and paint from metals
- Steel, .88 lbs.
- DIN 5133

Description	Art #
Pick Hammer	071582400

REPLACEMENT PARTS FOR AUTOMATIC WELDER'S HELMET KONTRAST

Accessories/Spare Parts		
Description	Pack Qt.	Art #
External front cover lens	10	098470002
Internal front cover lens	5	098470004
Front cover lens frame	1	098470012
Headband 4-fold adjustable	1	098472012



Helmet no longer available

REPLACEMENT PARTS FOR AUTOMATIC WELDER'S HELMET KONTRAST PLUS

Accessories/Spare Parts		
Description	Pack Qt.	Art #
External front cover lens	10	098470002
Internal front cover lens	5	098470004
Front cover lens frame	1	098470012
Headband 4-fold adjustable	1	098472012



Helmet no longer available

REPLACEMENT PARTS FOR WÜRTH SATELLITE WELDING HELMET

Accessories/Spare Parts		
Description	Pack Qt.	Art #
External front cover lens	2	098468002
Internal front cover lens	5	098470004
Front cover lens frame	1	098470012
Headband 4-fold adjustable	1	098472012



Helmet no longer available

SELF-IGNITING MULTI-FUNCTION HEAT TOOL



Description	Art #
Self-Igniting Tool	1702614

- Designed for automotive and truck repairs, electrical components, electrical panels, circuit board repair, heat shrink tubing, silver solder, cutting nylon rope, foam and much more
- No cords, so it can be used anywhere
- Equivalent to 120 watt soldering iron & 2500°F (1300°C) torch
- Ready to use 30 seconds after ignition
- 4 hours run time on each fueling
- See-through fuel tank

TURBO-LITE

- A specially designed electronic piezo lighter with windproof and weatherproof flame
- Electronic ignition system with safety locking switch
- Powered by standard cigarette lighter butane fuel
- Adjustable flame for low or high temperatures up to 2500°F (1300°C)
- 30 minutes run time on each fueling

Description	Art #
Turbo-Lite	1702612



ULTRATANE BUTANE FUEL

- Triple refined formula reduces clogging of filters
- Special vapor pressure promotes consistent ignition
- Contains no CFC's, canister with single-piece universal filling tip
- 15/16 oz. (26.5 grams)
- UPS shippable

Description	Art #
Ultratane Butane Fuel	1892702



ULTRA-THERM HEAT GUN



- Designed for industrial use where high volume heat is required
- The wide nozzle and high-output long life catalyst provide for infinitely adjustable heat levels in a completely portable tool
- The included deflector attachment makes large heavy wall heat shrink tubing a snap to install
- Can be used almost anywhere you would use a corded heat gun, except NO EXTENSION CORD

Description	Art #
Ultra-Therm Heat Gun	1702613

HAND HELD MICRO TORCH

- Adjustable high output flame runs a minimum of 60 minutes on each refueling
- Flame temperature up to 2500°F (1300°C)
- Piezo electronic ignition system with internal brass and ceramic parts ensure precision operation and long life
- Body constructed of hi-tech polymers providing a sturdy, yet lightweight feel

Description	Art #
Hand Held Micro Torch	1702616



PROFESSIONAL HEAT GUN

- Perfect for use with the Dent Lifter Kit
- Stripping and spot drying paint
- Bending and forming plastics
- Speed drying parts
- Removing floor tiles
- Loosening nuts and bolts
- Shrink tubing and packaging
- Shaping vinyl for installation
- Powerful high speed universal motor
- Sturdy die cast housing
- C-UL-US Listed. Made in USA
- Adjustable non-slip stand

Features:

- 1740 Watts
- Weight: 3.5 lbs.
- Temperature settings from 500°F - 750°F
- Airflow of 23 CFM at 3000 FPM
- Built-in hand and switch guard
- 6 feet of oil-resistant, grounded neoprene 3 wire cordset
- Double protected element housing
- Wrap-around air intake allowing it to draw air from any position



Description	Art #
Heat Gun	0702600
Replacement Heat Element	0702603

ECONOMY HEAT GUN

- Spot dry paint and primers
- Remove weather stripping without damage to doors
- Soften vinyl tops to stretch material over short areas and remove wrinkles and bubbles
- Soften undercoating for easy removal
- Remove and replace decals
- Speed cure body fillers & cements
- Thaw frozen door locks, radiators
- Loosen rusted fittings
- Shrink seat covers for a perfect fit
- Apply shrink tubing
- Remove adhesive backed side mouldings

Features:

- Two heat settings: 500°F & 1000°F
- Lightweight, 1 lb., easy to hold for long periods of time
- Built-in hand guard
- UL listed, safety agency tested & approved for user safety
- Thermoplastic case for high impact durability
- Built-in stand, very stable, allows user to set heat gun down in an upright position



Description	Art #
Economy Heat Gun	0702590

08.0510

ELECTRIC GLUE GUN

- Used for wood, plastic, metal, ceramics, magnets, leather, paper, cloth and other porous and non-porous materials
- Melts glue twice as fast as regular full size glue guns
- Double heater
- 80 watts of heating power
- Dries in 60 seconds
- No clamping or clean-up required
- Use with Dent Lifter Kit



Description	Art #
Electric Glue Gun	0702100057

GLUE STICKS

- Special adhesive sticks designed for WÜRTH dent repair systems
- All hot-melt adhesives are UV aging and water-resistant

		
Designation	High-Strength Hot-Melt Adhesive	Universal Hot-Melt Adhesive
Color	transparent light brown	black
Length	195 mm	180 mm
Dia. of hot-melt adhesive	11.5 mm	11.5 mm
Content	10 pc.	24 pc.
Package Qty.	180 g.	500 g.
Art. #	0890100050	1890100055
Brief Description	High tensile strength and hardness make it best suited toward small dents. The adhesive material is hygroscopic.	Easiest removal of hot-melt adhesive. Optimum for adapters with a diameter of 21 mm or more. Good adhesion on painted surfaces.
Technical Data		
Basis	polyamide thermoplastic	polymer-based connection
Density	0.89 g/cm ³ at +68 °F	0.96 g/cm ³ at +68 °F
Melting point	+275 °F	+185 °F
Application temperature	+356 °F - 392 °F	+374 °F - 410 °F
Processing time	20 seconds	20 - 45 seconds
Hardening time	30 seconds	30 - 50 seconds
Shore A hardness	77	40 ± 20
Bonding strength	up to 6.5 N/mm ²	up to 2.7 N/mm ²
Shear strength	up to 3.5 N/mm ²	1 - 1.5 N/mm ²
Tensile strength	up to 140 kg/cm ²	up to 43 kg/cm ²
Viscosity	10,000 - 18,000 nPas	6,700 nPas
Thermal stability	+257 °F	+158 °F
Resistance to cold	-4 °F	14 °F
Shelf life	24 months	24 months

FLUORESCENT WORK LIGHTS WITH ROUGH SERVICE BULB

Cord Light	Switch in light head	Switch in handle	With tool tap outlet	Reel	In line ballast	Cord	Art #
25'	No	Yes	Yes	No	No	16/3	08272550
25'	Yes	No	No	No	Yes	18/2	08272554
30'	No	Yes	Yes	Yes	on reel	16/3	08273006
40'	Yes	No	No	Yes	Yes	18/2	08274023
40'	No	Yes	Yes	Yes	on reel	18/3	08274042
50'	Yes	No	No	No	Yes	18/2	08275018
50'	No	Yes	Yes	No	No	16/3	08275019
N/A	No	Yes	Yes	—	—	—	08279639
30'	N/A	N/A	N/A	Yes	N/A	16/3	08273000

- All parts above the end cap are clear material to maximize light output
- Twin spring steel hook with cushion tips is standard
- Tool tap is located away from light head and hands
- Drip guard protects tool tap when not in use
- Three-way cushion located at top end of the lamp provides same light as 100 watt incandescent
- Large bumpers on handle to protect the light if dropped
- Convenient on-off button inside of handle to protect from dirt and grease
- Compact ballast is located in handle to eliminate ballast box on the cord
- Heavy duty oil resistant cord
- Rough service bulbs standard equipment - rated at 10,000 hrs.

ROUGH SERVICE DROPLIGHT BULBS

Description	Art #
50w, 130v Standard	17200050
100w, 130v Standard	172000100
75w, 130v Standard	17200070
75w, 130v Toughcoat*	172000701

*Toughcoat shatter-resistant bulbs reduce liability risks and enable you to comply with FDA and OSHA requirements. Used in automotive drop cords, mechanic trouble lights, extension cords and anywhere else the risk of severe shock may be encountered.



ROUGH SERVICE DROPLIGHT BULBS

- Single-ended plug in base with integral starter and interference suppressor
- Up to 75% less energy cost and heat compared to incandescent lamps
- It's 13w equals 60w of incandescent
- Helps conform to OSHA requirements
- Made in the USA
- Article # 1720 62000 is silicone injected at the base where standard bulbs fail - rated 10,000 hours



Description	Art #
13w Professional Silicone Injected - Rough Service	172062000
13w Economy	07203900

STANDARD DUTY WITHOUT TOOL TAP

Description	Art #
25' Cord	08272554
50' Cord	08275018
Replacement Lens	08271000

HEAVY DUTY WITH TOOL TAP

Description	Art #
25' Cord	08272550
50' Cord	08275019
Replacement Lens	08272000

HEAVY DUTY ON REEL WITHOUT TOOL TAP

Description	Art #
without outlet	08274023

HEAVY DUTY ON REEL WITH TOOL TAP

Description	Art #
30' Reel	08273006
40' Reel	08274042



TRIPLE TAP REEL WITH CIRCUIT BREAKER

Description	Art #
30' Reel	08273000



CONVERT A LIGHT

- Easily converts from incandescent to fluorescent.

Description	Art #
with Ballast	08279639
without Ballast	08279666



UV LIGHT PROBE WITH UV GLASSES

- Flexible wand gets into tight areas.
- 4 True LED bulbs
- Bright LED technology illuminates brilliant fluorescent glow
- Comfortable ergonomic grip with E-Z access on/off button
- Fluorescent enhancing safety glasses
- 100,000 hour bulb life

Description	Art #
UV Light Probe w/ UV Glasses	1827560



27 LED CORDLESS WORKLIGHT

- Designed to eliminate the need for a corded light
- Slim design allows for easy access to tight places
- Impact resistant polycarbonate tube with non-slip handle
- Produces very little heat, therefore eliminating the possibility of burns to the technician or vehicle components during continuous use
- 27 Super-bright, long-life LEDs provide forward directed pure white light
- Swivel Friction Hook: Swivel hook design allows the light to be positioned in any direction
- Rechargeable: Provides up to 5 hours of continuous operation
- Replaceable board and components
- Charger Included
- Proudly made in North America
- 1 Year Limited Warranty • 60 mAH Battery



Description	Art #
27 LED Cordless Worklight	0764000751

COLD SHRINK TAPE

- Water resistant
Your advantages:
 - The shrink tape provides various materials with a water and steam proof seal
- Good insulation properties
Your advantages:
 - Thanks to its disruptive strength, the tape is highly suitable for insulating cables and electrical lines
- Highly compatible with any insulation and sheathing materials
Your advantages:
 - Good compatibility with PE, PVC, butyl, neoprene etc. allows to be used in many different areas in the automotive and electrical fields
- Highly elastic
Your advantages:
 - The tape can be stretched considerably and nestles very close to the material to be processed

Applications

- Sealing of pipes and hoses
- Emergency sealing of radiator and gas hoses
- Insulation of electrical lines and cables
- For use in places where heat shrink tubes can no longer be used
- Bundling lines

Base material	Polyisobutylene (black)
Elongation at tear	600%
Application temperature	41 °F to +95 °F
Temperature resistance	-40 °F to +194 °F
Disruptive strength	40kV/mm
Shelf life (at approx. 68 °F and 50% humidity)	24 months (store dry, lying and dust-free)
UV resistance	conditional
Moisture resistance	given



Notes on application

- The surfaces to be sealed must be dry and free of dust and grease
- Remove PVC cover foil and stretch the tape considerably
- To achieve problem-free adhesion and a water-proof seal, wrap the tape tightly around the material to be processed and then overlap
- The shrink tape is only conditionally UV-resistant and should therefore be protected from direct sunlight

Description	Art #
Cold Shrink Tape	19850771

BRUSHABLE ELECTRICAL TAPE

- 4fl oz. brush can
- Protects vehicle wiring from all weather conditions as well as corrosion from salt and calcium
- Flexible waterproof coating
- Easy to use brush applicator
- Coats, seals and insulates
- Won't crack, fray or unravel like tape
- Great for hard to reach areas

Description	Art #
Brushable Electrical Tape	0893198010



ELECTRICAL TAPE

- Plasticised PVC tape with good mechanical and electrical properties
- UL/CSA listed for use in electrical insulation application
- Having a modified rubber-resin adhesive coating provides good ageing resistance and high adhesion strength
- Suitable for most electrical insulation application in the building, construction, automotive, cycle and marine industries
- Also useful in sealing, binding, protection and decorative application
- Size roll: 3/4 x 60'
- Thickness: 7 mil.
- High quality electrical tape for all your electrical needs
- Suitable for use at no more than 600v and not more than 176 ° F
- 10 rolls per sleeve



Description	Art #
Electrical Tape	1985615

IMPORTED ELECTRICAL TAPE

- VDE-tested according to DIN EN 60454-3-1 Type 5
- Your advantages:
 - Safety thanks to tested properties
 - Up to 9kV disruptive strength
 - Hardly flammable
- Safe, easy use
- Your advantages:
 - Tear-proof and resistant to aging
 - High flexibility and adhesive strength
- Following assembly, consistently positive properties, even at changing temperatures
- Largely resistant to diluted acid and caustic solution

Application

For insulating, marking electrical cables and securing cable harnesses etc.

Note:

Protect tape from exposure to direct sunlight.



Description	Art #
Imported Electrical Tape	09856

Chemical basis	Acrylate, soft PVC foil
Thermal stability	32°F to +194°F
Disruptive strength	9 kV
Minimum shelf life	24 months

3M® LINERLESS ELECTRICAL SPLICING TAPE

- Size roll: 3/4" x 15' x 0.030" thickness
- Moisture sealing
- Insulating
- Flame retardant

Description	Art #
3M Linerless Electrical Splicing Tape	1985617



08.0540

MOISTURE SEAL TAPE

- Size roll: 2.5" x 10' x 0.045" thickness
- Moisture proof connectors
- Tough vinyl backing prevents abrasion
- Protects terminal blocks
- Adds strain relief to splices
- Vulcanizes when both tape surfaces meet giving all season, all weather protection

Description	Art #
Moisture Seal Tape	1985616

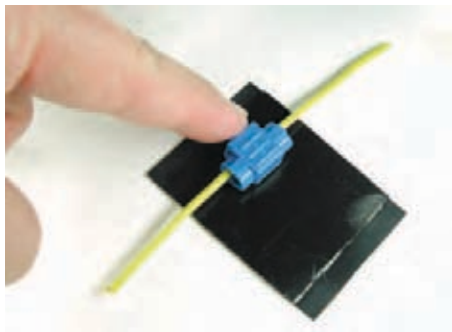

Place



Join Tape Surface



Sealed Permanently

BLACK CLOTH FRICTION TAPE

(Cotton cloth impregnated with a rubber based adhesive)

Applications:

Offers good mechanical protection against abrasion and penetration of low voltage cable, splices and wire. Used for insulation and protection of industrial harnesses and electrical wires from physical damage caused by friction.

Features/Benefits:

Black cotton cloth with non-corrosive rubber resin adhesive. It's cloth backing makes this tape easily torn by hand and extremely conformable. Highly resistant to humidity and galvanic corrosion. For contractors who demand a consistent, trouble-free product.

Performance Specifications:

- Maximum Temperature of 176 ° F
- Dielectric Strength of 1,000 volts

Description	Art #
Black Cloth Friction Tape	1985616



TAPE

	Style	Width	Roll Yard	Art #
1	Nylon Filament Tape	3/4"	60	199230030
2	Premium Duct Tape - Grey	2"	60	199230040
	Economy Duct Tape - Grey	2"	60	199230042
3	Premium Duct Tape - Black	2"	60	199230041
	Economy Duct Tape - Black	2"	60	199230043
4	Packing Tape (Brown)	2"	55	199270
5	Clear Label Tape	4"	72	199260
6	Clear Label Tape	2"	55	199271
7	Clear Heavy Duty Label Tape	2"	55	199275



- Low tensile, economical fiberglass reinforced filament tape, with an aggressive high shear resistant adhesive system
- Used for palletizing and unitizing corrugated and paper board boxes
- Non-critical bundling applications

Art. # 199230030					
Backing material	Type of adhesive	Total thickness	Adhesion to steel	Elongation at break	Tensile strength
Glassfiber & BOPP	Synthetic rubber	101.6 um 4.0 mils	7.6 N/cm 69.4 oz/in	4%	193 N/cm 110.2 lbs.

- 10 mil light industrial grade cloth duct tape used to seal cartons, bind books, repair seats, bundle wires, splice, repair and seal hatch covers and cargo doors in the shipping industry
- Use as a condensation barrier in appliance assemblies
- Tested in accordance with UL 723
- Used in industrial, construction, auto and marine markets

Art. # 199230040			
	Standard	Metric	ASTM Test Method
Tensile strength	27 lbs/in width	47.3 N/10 mm	D 3759 D 3759M
Adhesion to Stainless Steel	50 oz/in width	5.47 N/10 mm	D 3330 D 3330M
Thickness	10 mils	0.25 mm	D 3652 D3652M
Elongation	15%	15%	D 3759 D 3759M
Service Temperature Min	50 °F	10 °C	N/A
Service Temperature Max	200 °F	93 °C	N/A

TAPE (CONTINUED)

- 8 mil economy cloth duct tape used for packaging, bundling, sealing, seaming, repairing, holding and waterproofing
- Good adhesion characteristics
- Used in industrial, auto and marine markets

Art. # 199230042			
	Standard	Metric	ASTM Test Method
Tensile strength	20 lbs/in width	35.0 N/10 mm	D 3759 D 3759M
Adhesion to Stainless Steel	45 oz/in width	4.93 N/10 mm	D 3330 D 3330M
Thickness	8.0 mils	0.20 mm	D 3652 D3652M
Elongation	15%	15%	D 3759 D 3759M
Service Temperature Min	50°F	10°C	N/A
Service Temperature Max	200°F	93°C	N/A

- 10 mil light industrial grade cloth duct tape used to seal cartons, bind books, repair seats, bundle wires, splice, repair and seal hatch covers and cargo doors in the shipping industry
- Use as a condensation barrier in appliance assemblies
- Tested in accordance with UL 723
- Used in industrial, construction, auto and marine markets

Art. # 199230041			
	Standard	Metric	ASTM Test Method
Tensile strength	27 lbs/in width	47.3 N/10 mm	D 3759 D 3759M
Adhesion to Stainless Steel	50 oz/in width	5.47 N/10 mm	D 3330 D 3330M
Thickness	10 mils	0.25 mm	D 3652 D3652M
Elongation	15%	15%	D 3759 D 3759M
Service Temperature Min	50°F	10°C	N/A
Service Temperature Max	200°F	93°C	N/A

TAPE (CONTINUED)

- Performance grade, biaxially-oriented polypropylene carton sealing tape
- Characteristics include good impact resistance, very good adhesion and shear resistance on most carton surfaces
- Use for carton sealing, light bundling
- Meets CID A-A-1684C specification

Art. # 199270				
Backing material	Type of adhesive	Total thickness	Adhesion to steel	Elongation at break
PP film	Synthetic rubber	40 um 1.6 mils	4.8 N/cm 43.9 oz/in	165%

- Moisture-proof label protection tape for industrial and production laminating, joining, protecting, covering
- Resists bacteria, fungi, solvents, weathering and yellowing
- Use on industrial and auto markets

Art. # 199260			
	Standard	Metric	ASTM Test Method
Tensile strength	20 lbs/in width	35 N/10 mm	D 3759 D 3759M
Adhesion to Stainless Steel	23 oz/in width	2.52 N/10 mm	D 3330 D 3330M
Thickness	1.8 mils	0.05 mm	D 3652 D3652M
Elongation	140%	140%	D 3759 D 3759M
Service Temperature Min	-20°F	-29°C	N/A
Service Temperature Max	180°F	82°C	N/A
Application Temperature Min	20°F	-7°C	N/A
Application Temperature Max	110°F	43°C	N/A
Adhesion to backing	15 oz/in width	1.73 N/10 mm	D 3330 D 3330M
Adhesion to Kraft	9 oz/in width	0.89 N/10 mm	D 3330 D 3330M

PTFE TAPE

- For sealing pipe joints
- DIN DVGW tested oxygen approved
- Resistant against all aggressive media
- Temperature resistant from 32°F to +500°F
- No sticking or swelling, preventing seizing of threads
- Threaded connections can easily be loosened even after years of service
- DVGW-tested (thickness: 0.1 mm) pursuant to DIN EN 751/3 (97) and DIN 30660 (99)

Description	Width	Length	Thickness in mm	Surface-based mass g/m ²	Pack. Qty	Art. #
PTFE Thread Sealing Tape	5/8"	13.2 yards	0.08	25	10	0985030165



PACKAGING TAPE DISPENSER

- Easy to load, durable with anti-reverse bar and blade safety guard for 2" width maximum use
- Ideal for carton sealing
- Recommended

Description	Art #
Packaging Tape Dispenser	1985051



HOOK & LOOP FASTENER (ADHESIVE BACK)

VELCRO™ tapes can be attached to end products by a variety of methods, including:

- Sewing (most commonly used).
- Adhesives incl. pressure sensitives.
- Dielectric (heat sealing w/adhesives).
- Heat activation.
- Ultrasonic (welding by molecular vibration).
- Mechanical.

Description	Size	Art #
Hook & Loop Fastener	3/4"	189434

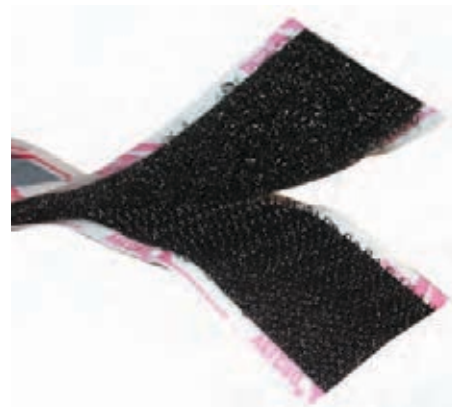

DUAL LOCK FASTENER (ADHESIVE BACK)

Backing/Attachment:

- Pressure sensitive very high bond Scotch VHB acrylic adhesive.

Dwell Time:

- 48 hours minimum, 72 hrs for max. performance.

Operating Temperature:

- -20°F (-29°C) -158°F (70°C) continuous & -20°F (-29°C) -200°F (93°C) intermittent.

Description	Size	Art #
Dual Lock Fastener	1"	1894201



STAINLESS STEEL SAFETY LOCK WIRE

Gauge	Weight	Art #
.032	1 lb.	17709507



BENCH GRINDING WHEEL

- For general purpose metal grinding and finishing
- Wheels are individually precision ground and balanced, true and faced smooth operation
- All wheels are speed tested
- Includes nested bushings
- 6" x 1" x 1"
- Comes with adapters to fit 1/2", 5/8" and 3/4" arbors

Description	Art #
Bench Grinding Wheel	16799150



BENCH WIRE WHEEL

- For general purpose brushing of uneven or difficult-to-reach surfaces
- May be used individually or stacked on a shaft
- A dense, high quality tempered carbon steel crimped wire construction (.014" diameter)
- 6" quality crimped wire wheel
- Use to smooth rough edges, clean rust and paint and scale removal. Used to roughen surfaces to increase adhesion.
- Maximum 6,000 RPM
- 1/2" - 5/8" arbor hole

Description	Art #
Bench Wire Wheel	16799160



MECHANIC'S SAFETY WIRE

- 18 gauge is good for Body Shops. (Hanging up parts to be painted)

Gauge	Weight	Art #
18	5 lbs.	17709505
18	2 lbs.	17709506

- 14 gauge is good for mechanical shops. (Hanging brake calipers, exhaust, etc.)

Gauge	Weight	Art #
14	5 lbs.	17709508
14	2 lbs.	17709509



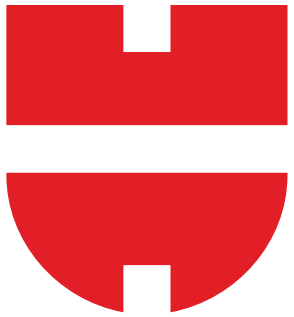

WÜRTH

REUSABLE SEAT COVERS AND FLOORMATS



These seat covers and floormats are an environmentally-conscious alternative to using disposable plastic. Also, they are cost effective since they can be washed and re-used many times over.

FEATURES

Crafted with durable and long lasting polypropylene material

- Machine washable for continued use
- Keeps your customer's car seat clean of dirt and oil

Environmentally-conscious alternative

- No wasted disposable plastic
- Re-usable and cost effective



Description	Art #
Seat Cover	0WGE900100
Floormat	0899500070



PLASTIC MASK SHEETING / CAR COVERS

Size	Art #
12' x 400' Sheeting	089977040
.9 ml Large Car Cover - 6.5' x 25' - 25/Roll	089977020



WHEEL MASKERS

- Protects tire & wheel while painting
- Chemical resistant
- Anti-static additive
- No slip surface on both sides
- 100 per box

Description	Art #
Wheel Maskers	089977030



FLOOR MATS

- 500 mats per box
- Rugged, plastic coated paper
- Generous size, 17" x 22"

Description	Art #
Floor Mats	189950036



STEERING WHEEL COVER

- 100 per box
- Keeps steering wheel clean
- Reusable, form fitting
- Chemical resistant

Description	Art #
Steering Wheel Cover	1899500201



DISPOSABLE SEAT COVERS

- 200 covers per roll
- Keeps upholstery clean
- No slip surface on both sides
- Chemical resistant
- 1mm thickness
- Extra large cover fits high back seats

Description	Art #
Seat Covers	189950011
Dispenser	089950006

WRECK WRAP

- Vehicle interior is protected from rain, snow, and UV rays
- Adhesive does not transfer to the body of the vehicle when removed
- Film cutter is included
- Great for collision center storage lots!

Size	Art #
18" x 100' Roll (includes 2 rolls)	189977051
36" x 100' Roll	189977050



PROTECTIVE SHEETING

This high density paintable plastic sheeting is corona treated and provides superior protection from overspray and other contaminants. These airborne contaminants adhere to the protective sheeting without flaking and prevent contamination of wet paint during the painting process.

- Clings to vehicle to prevent sheeting from lifting
- Clearly marked paintable side
- Cut to desired length
- Tear resistant, recyclable plastic
- Ultimate bleed through resistance against penetration of solvents, even paint stripper
- HDPE (high density polyethylene) is twice the strength of LDPE (low density polyethylene)
- Dispenser box keeps sheeting clean, free of dust, dirt and other contaminants

Size	Art #
16' x 350' Roll	1899600400



SORBENT PADS

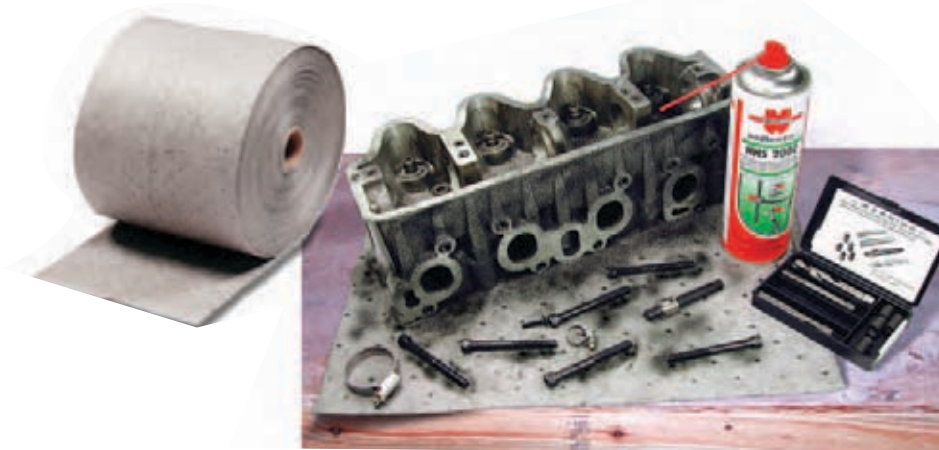

Size	Art #
15" x 100' Roll (New Larger Roll)	08858916

- This unique sorbent pad absorbs **all liquids**
- Use on top of work bench for cleaner repairs
- Prevent employee slippage on oily floors
- Grips floor for Safety/Top and bottom layers of FineFiber are built of densely woven, small-diameter strands of fiber to increase surface area - enabling the Mat to grip the floor and secure it for safer walking
- Virtually indestructible/FineFiber Mat has a layer of MeltBlown polypropylene ultrasonically sandwiched between two FineFiber layers. 3-ply construction resists heavy foot traffic
- Multi-Perforations save you money. Rolls are perforated every 7.5" vertically and every 17" horizontally
- Helps you comply/29 CFR 1910.22(a)(2), 29 CFR 1910.107(b)(3), 29 CFR 1910.107(g)(2), 29 CFR 1910.120 (j)(1), 29 CFR 1910.1450 (e)



OIL ONLY SORBENT PADS

- Grips floor for Safety/Top and bottom layers of FineFiber are built of densely woven, small-diameter strands of fiber to increase surface area - enabling the Mat to grip the floor and secure it for safer walking
- Virtually indestructible/FineFiber Mat has a layer of MeltBlown polypropylene ultrasonically sandwiched between two FineFiber layers. 3-ply construction resists heavy foot traffic
- Multi-Perforations save you money. Rolls are perforated every 7.5" vertically and every 17" horizontally
- Helps you comply/29 CFR 1910.22(a)(2), 29 CFR 1910.107(b)(3), 29 CFR 1910.107(g)(2), 29 CFR 1910.120 (j)(1), 29 CFR 1910.1450 (e)
- Will not absorb water
- Great for boat bilges

Size	Art #
15" x 100' Roll (New Larger Roll)	08858914



DRUM TOP SORBENT PAD

- Clean Living/Absorbs drips from leaking pumps and helps keep drum storage areas looking good
- Bung Hole Access/Pre-cut bung holes make for easy access to drum. Pads can be removed and replaced with pumps and valves installed
- 25 pads per pack

Did You Know...

- Clay doesn't really absorb: the clay just gets coated with the liquid
- Clay is a known health hazard: Read the warning on the bag. Clay can cause lung damage
- When all is said and done, clay costs more to use and dispose of
- Clay becomes very sticky when used, sticks to your shoes and tracks throughout your shop

Size	Qty.	Art #
55 Gallon Drum Top Sorbent Pad	25 Pack	08858913
30 Gallon Drum Top Sorbent Pad	25 Pack	08858912



PARTS BAGS

- 500 per roll



Size/Description	Art #
11" x 18"	189990021
14" x 22"	189990022
Universal Dispenser	089990020

ZIPLOC® PARTS BAGS

- Heavy duty
- White block area to write on

Size	Art #
3" x 5"	189908



DISPOSABLE KEY TAGS

- Made of laminated paper
- Eliminates having piles of keys to sort
- Gives a professional look and saves time for other duties
- Pliable and easy to write on
- Will accept pen or felt marker
- 100 per pack



Description	Art #
Disposable Key Tags	1791100

MICROFIBER DETAILING CLOTH

The super-absorbency and magnetic “clinginess” of the microfiber fabrics make it especially well suited for cleaning and beautifying automobiles.

Great for Cleaning:

- Windows
- Car Interiors
- Leather
- Chrome
- Rubber and Plastic
- Monitors



Description	Art #
Microfiber Detailing Cloth	1899810

SPECIAL CLEANING CLOTH

- Can be used as a polishing cloth
- Extremely tear resistant, even when wet
- Solvent-resistant
- Fast lint-free
- Very absorbent
- Washable, wringable and reusable
- Safe for food
- Use with Dent Lifter
- Used in car, boat and industrial cleaning



Design	Size	Art #
White, 1-ply (size cloth)	11" x 15"	0899800901

ONE WIPE

- Professional Quality, All-Purpose Bonded Cellulose Wipers
- Performance for a wide variety of wiping tasks
- Versatile Leading All-Purpose Substrate
- Ideal for general purpose wiping
- Ultra Absorbent
- Soft Hand Feel
- 225 wipes per box
- Dimensions per wipe - 9" x 12"



Description	Art #
One Wipe	189986886

SMOOTH BLUE WIPE

- Professional Quality, High-Performance Spunlace Towels
- Highly Absorbent
- Chemically Pure
- Reusable Cloth-like towels
- Solvent Resistant
- Superb Wet Strength and Wipe Dry Performance
- Virtually Lint Free
- Textile Performance for the toughest, low lint wiping tasks
- 125 wipes per box
- Dimensions per wipe - 9" x 17"

Description	Art #
Smooth Blue Wipe	189992131



WURTH VALVE ADJUSTING TOOLS

- Each blade thickness has a different color, so the blade required can be found easily
- The blade thickness is injected in the plastic handles and therefore cannot blur
- Blade width 13mm, length 45mm, total length 100mm

Color	Thickness mm	Art #
Purple	.10	07135122
White	.15	07135123
Blue	.20	07135124
Grey	.25	07135125
Yellow	.30	07135126



STUD EXTRACTOR

- For removing broken-off studs or threaded bolts. A hole is bored into the parts to be removed according to the Table and the extractor is screwed in to the left. By means of further tightening the broken-off part is extracted without damaging the thread.
- Chrome Vanadium, forged
- Comes in plastic box

Size	Art #
15mm, dimensions 1-5	0695684353



STUD DRIVER AND REMOVER

- For rapid fitting and removal of stud bolts with or without thread.
- No damage to bolt through welding on of turning aids (nuts, etc.) or use of pliers.
- No lock nuts needed.
- Positive grip on studs from 10mm long.
- No wearing parts.
- Diameter 25mm, 65mm long.

Applications:

- All motor vehicles, agricultural and building machinery maintenance, fleet operators, motorcycle dealers, motor and mechanics; engineering, boat building, etc

Fits Stud Size	Art #
4 pc. Set	06904211
Set Includes: 6, 8, 10 and 12mm	



PLASTIC LINED LUG SOCKETS

- Special design will not mar expensive mag wheels
- Available in 3 sizes for most common lugs
- Plastic sleeve and plastic liner cap
- 1/2" drive

Wrench Size	Art #
3 pc. Set	0713132890
Set Includes:	
17 mm	0713132817
19 mm	0713132819
21 mm	0713132821
Plastic Cover	0713132891



WURTH PIN PUNCH SET

- Chrome vanadium air hardened steel
- Tempered safety striking heads will not burr or split
- Shaft all hardened, making it extremely tough and durable
- Includes plastic case

Description	Art #
Set includes diameters 2, 3, 4, 6 and 8	07146341



A/C DYE & OIL CARTRIDGE GUNS

- For use with cartridges of A/C dye and A/C oil
- Pre-calibrated to dispense exact amount needed

Description	Art #
8 oz. Cartridge Gun	0891764100
Quickshot Gun	0891764010



DYE SERVICE LABELS

- Affix label to notify the next service technician that dye is present

Description	Art #
8 labels	08929825



FLUSH GUN

- Flow control flush gun for A/C Super Flush Art. # 0892 76402.

Description	Art #
Flush Gun	08911300
A/C Super Flush	089276402



A/C RETROFIT SOCKETS

- 1/4" drive for octagon R-134a port adapters
- Includes both low & high side sockets

Description	Art #
A/C Retrofit Sockets	076400028



A/C DYE INJECTOR ADAPTERS

R-12 Adapter

- Used on older vehicles with R-12 refrigerant. Works with R-134A adapter

R134A adapter hose

- Works in conjunction with the A/C Dye Injection System. Installs on A/C dye cartridge Art. # 0892 764 030



Description	Art #
R-12 Adapter	0764000019
R-134A adapter hose	0764000015

A/C GOO TAPE

- Insulates exposed A/C pipes, tubing, fittings & prevents condensation build-up

Description	Art #
A/C Goo Tape	19852010



CAN TAP HOSE

- Use with Art. # 1892 764300 A/C Leak Stop with Dye
- Hose Length 9"

Description	Art #
Can Tap Hose	0892764305



3 IN 1 SIDE MOUNT CAN TAP

- Use with Art. # 1892 764300 A/C Leak Stop with Dye

Description	Art #
3 in 1 Side Mount Can Tap	1892764307



WURTH STORAGE TRAYS

- Holds 2 part and single cartridges upright and secure.
- Enables user to organize according to their specific needs.
- Order trays separately to retrofit customers' current Aerosol Cabinet.
- Allows user to store partially used cartridges with nozzles attached.

	Description	Art #
1	Chemical Cabinet	19665
2	Aerosol Cabinet	1955900
3	Plastic Repair Poster	19992223
4	Storage Trays	19669100
5	Velcro Buttons	1999372



WURTH BULB RACK

- 4 rows of clear dispenser drawers with adjustable dividers plus a hidden storage area

Width	Height	Depth	Art #
19"	26-3/4"	4"	1966720
Replacement Tray			19667211



HOSE DISPENSER

- A high quality, wall mountable, tubing dispenser system specifically constructed for use with spool mounted hose
- A convenient ruler on the front of the rack to aid in measuring
- No hose entanglement during unreeling
- No disarray when stocking different types of hoses

Description	Art #
Hose Dispenser	189510



HOSE RACK

- A six position rack created to hold fuel line and wiper tubing
- Free standing or wall mountable

Description	Art #
Hose Rack	189511



WIRE SPOOL RACK

- High quality design for the convenient storing and dispensing of spool wire
- Mount on counter, wall or work vehicle with use of lag holes and keyhole slots
- All steel construction, with a red baked enamel finish
- Convenient carrying handle on single rod model
- Plated steel rods for heavy spools

Width	Height	Depth	Art #
26-1/8"	10-3/8"	5-3/4"	1770900150 (6 rolls)
26-1/8"	17-7/8"	5-3/4"	1770900151 (12 rolls)



DOS RACK

- Holds DOS system bottles
- Mount on tool box, work bench or wall

Description	Art #
DOS Rack - 7 Compartment	0891271
DOS Rack - 14 Compartment	0891273141



ORSY® WIRE REEL SYSTEM

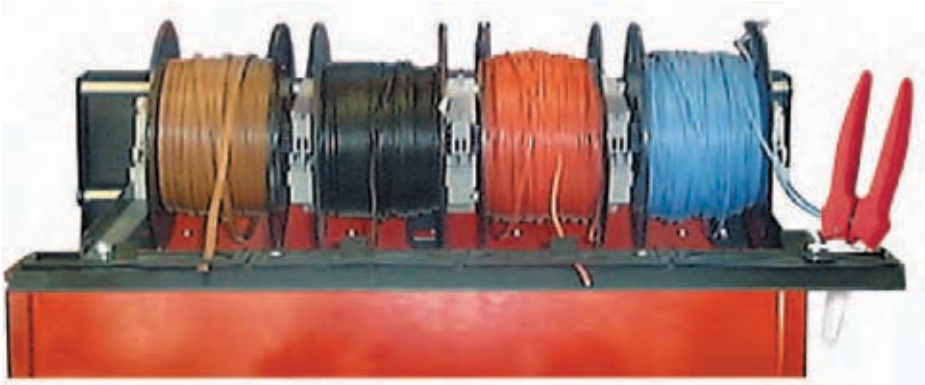

Dispenser Includes:

- Dispenser assembly
- 5 reel holders - Art. # 0956 10903
- 8 small stars (holds 4 rolls) Art. # 0956 10901
- Mounting hardware

Note:

- Order wire separately.
- Combination shears sold separately Art. # 0714 0314.

Description	Art #
Small Dispenser	0956109
Large Reel System Stars	095610902
Small Reel System Stars	095610901
Reel Holder	095610903
Coil Core Plastic Insert	095610904

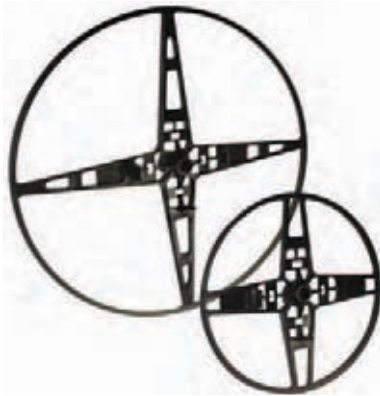

CABLE TIE RACK

- For fast, easy and reliable bundling of wires, cables, looms, hoses, etc.
- Preformed leading edge allows fast insertion into buckle
- Absolutely secure with long life
- Resistant to cold, will not crack or deteriorate
- Flame resistant
- Resistant to oil, fats, solvents and many organic substances. Caution when in contact with strong mineral acids and/or oxidizing chemicals, especially at high temperatures

Material: PA 6.6

Temperature Range: -40° to 185°F

Durability:

- White: Weather resistant at normal temperatures. For internal applications.
- Black: UV resistant, due to carbon structure. The effect of UV rays is minimized.



Description	Art #
Cable Tie Rack	050205020

08.0670

LARGE ASSORTMENT BOX & INSERTS

- Organize and individualize your parts inventory to save time and money
- Various inserts offer a variety of compartments to organize parts
- A blank schematic is included within the assortment box
- Assortment boxes have positive latch locks to prevent loss of small pieces
- Assortment boxes are made of prime cold rolled steel with an acid/rust resistant black baked enamel finish
- Rounded scoops enables easy removal of small parts
- Handle for easy transporting to work site

	Description	Art #
1	Lg. Box w/ Adjustable Insert	195523013
2	Lg. Box w/ 6 Compartment Tray	09559502
3	Lg. Box w/ 12 Compartment Tray	195523012
4	Lg. Box w/ 16 Compartment Tray	195523016
5	Lg. Box w/ 20 Compartment Tray	195523020
6	Lg. Box w/ 24 Compartment Tray	195523024
7	Lg. Box w/ 32 Compartment Tray	195523032
	Extra Dividers (9 pack)	195523011

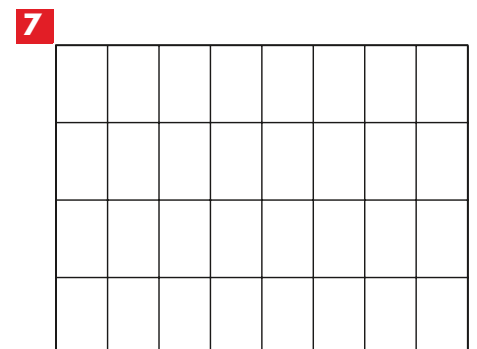
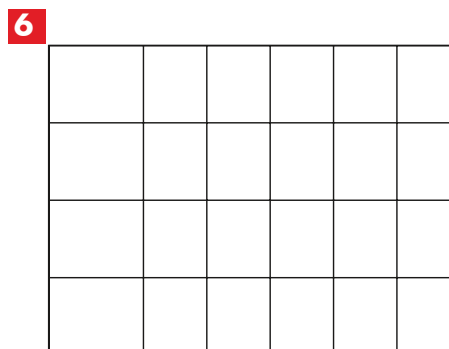
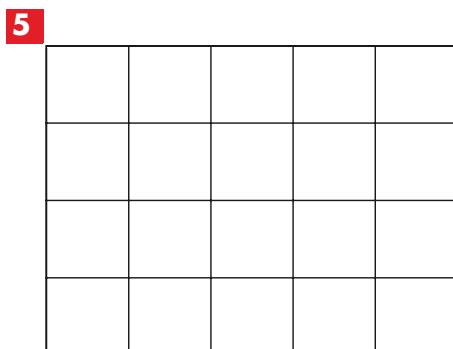
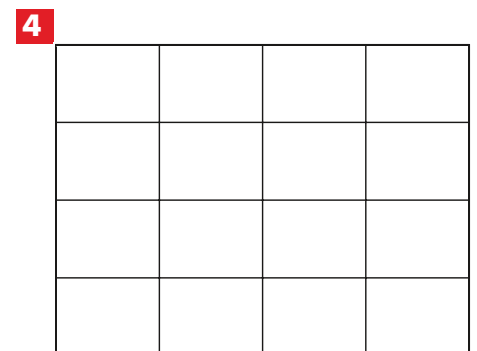
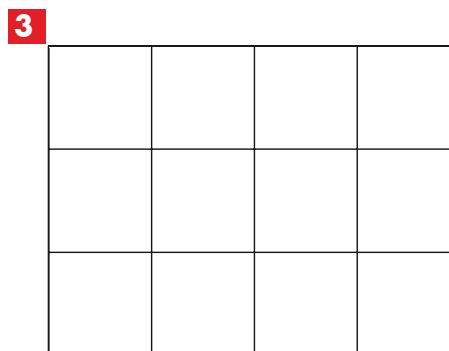

STORAGE

	Description	Width	Height	Depth	Drawer Width	Drawer Height	Drawer Depth	Extra Dividers	Stand Base	Art #
1	9 Drawer Storage Cabinet	17-1/4"	10-7/8"	11-5/8"	5-3/8"	2-3/4"	11-1/4"	196691		19669
2	Utility Storage Cabinet	19-7/8"	32-3/4"	14-1/4"						19665
3	4 Drawer Cabinet	20"	15"	15-3/4"					19551041	1955104
4	18 Comp. Storage Bin	24"	12-3/4"	4-3/4"						19662
5	36 Comp. Storage Bin	24"	24"	4-3/4"						19661
6	40 Comp. Storage Bin 9" Deep	33-3/4"	22-1/2"	9"	4"	4-1/2"			1966801	196640
6	40 Comp. Storage Bin 12" Deep	33-3/4"	22-1/2"	12"	4"	4-1/2"			1966131	196613

1

2

3

4

5

6

TOOL TROLLEY

- Large and lockable working surface on ball bearing guides
- Unobstructed access to center compartment, with adjustable dividers
- Drawer with ball bearing mechanism
- Sturdy steel construction, lacquer coated
- Working surface completely covered with oil resistant and shock proof rubber
- Round edges, PVC, coated handles
- Excellent quality - Made in Germany

Height	Width	Length	Art #
880 mm (34-5/8")	500 mm (19-3/4")	800 mm (31-1/2")	07159326



19" TOOL BOX

- Large sure-grip handle
- Extra deep bottom storage area
- Extra high lid for increased storage capacity
- Bottom feet keep box clean and dry
- Deluxe, lift-out tote tray
- Fully lockable

Dimensions	Art #
19"W x 9-1/2"D x 9-1/2"H	1695590651



CANVAS TOOL BAG

- Big enough to hold and keep all your necessary tools
- Internal metal frame holds bag wide open
- 10 outside pockets and 14 inside pockets to organize tools and accessories
- Made of rugged 20 oz. canvas material with a hard bottom for better stability

Height	Width	Length	Art #
11"	10"	12"	171593610



TOOL TOTE TRAY

- Large open compartment sample/tool tray with drawer and handle.

Description	Depth	Width	Length	Art #
Pull out drawer w/ 6 compartments	1-1/2"	12-1/2"	7-1/4"	
Overall Tool Tray		8-1/2"	14"	
Tool Tote Tray				071593311



NUISANCE DUST MASKS

- Effectively protects against non-toxic dust
- Doesn't interfere with breathing or speech
- NOT NIOSH approved
- 50 masks per box

Description	Art #
Nuisance Dust Masks	08991



HALF MASK RESPIRATOR

- Soft sealing flange and forward angled nosepiece easily accommodates eyewear
- Perspiration port reduces facepiece slippage and skin irritation
- Large inhalation port provides lower breathing resistance

Recommended Industries/Use

- Chemical
- Construction
- Food Services
- Forestry
- Manufacturing
- Mining
- Municipal Services
- Oil and Gas
- Steel and Metals
- Transportation
- Utilities
- Welding

Hazards

- Airborne Particulates
- Biohazard
- Chemical
- Contamination
- Gas, Vapors, Smoke

Regulations

- NIOSH 42 CFR 84



Description	Art #
Half Mask Respirator	18991430

ORGANIC VAPOR CARTRIDGES

- Cartridges and filters for Half-Mask and Full Facepiece respirators
- Twist Lock cartridges

Recommended Industries/Use

- Agricultural
- Chemical
- Construction
- Food Services
- Government
- Law Enforcement
- Forestry
- Manufacturing
- Medical
- Military
- Mining
- Municipal Services
- Oil and Gas
- Pharmaceutical
- Steel and Metals
- Transportation
- Utilities
- Welding
- Nuclear

Hazards

- Airborne Particulates
- Chemical
- Contamination
- Gas, Vapors, Smoke

Regulations

- NIOSH 42 CFR 84



Description	Art #
Organic Vapor Cartridges	18991431

N99 FILTERS

- Screw-on (threaded) cartridges

Recommended Industries/Use

- Agricultural
- Chemical
- Construction
- Fire Protection
- Food Services
- Government
- Law Enforcement
- Forestry
- Manufacturing
- Medical
- Military
- Mining
- Municipal Services
- Oil and Gas
- Pharmaceutical
- Steel and Metals
- Transportation
- Utilities
- Welding

Hazards

- Airborne Particulates
- Chemical
- Contamination
- Gas, Vapors, Smoke

Regulations

- NIOSH 42 CFR 84



Description	Art #
N99	18991432

P100 FILTERS

- Cartridges and filters for Half-Mask and Full Facepiece respirators
- Twist Lock cartridges

Recommended Industries/Use

- Agricultural
- Chemical
- Construction
- Food Services
- Government
- Law Enforcement
- Forestry
- Manufacturing
- Medical
- Military
- Mining
- Municipal Services
- Oil and Gas
- Pharmaceutical
- Steel and Metals
- Transportation
- Utilities
- Welding
- Nuclear

Hazards

- Airborne Particulates
- Chemical
- Contamination
- Gas, Vapors, Smoke

Regulations

- NIOSH 42 CFR 84



Description	Art #
P100	18991433

DUST FILTRATION MASK

- Multiple size options for wide range and improved fit
- Molded cup design
- Offered in valved
- Incorporate humidity-resistant filter media
- Low breathing resistance
- Lightweight design
- Durable suspension straps
- Optional boomerang nose seal or full seal for secure and comfort fit

Recommended Industries/Use

- Agricultural
- Chemical
- Construction
- Fire Protection
- Food Services
- Law Enforcement
- Forestry
- Manufacturing
- Medical
- Mining
- Municipal Services
- Oil and Gas
- Pharmaceutical
- Steel and Metals
- Transportation
- Utilities
- Welding

Hazards

- Airborne Particulates
- Biohazard
- Chemical
- Contamination
- Gas, Vapors, Smoke

Regulations

- NIOSH 42 CFR 84



Description	Art #
Dust Filtration Mask	189914141

DUST & MIST RESPIRATORS WITH EXHALATION VALVE

Easier breathing and less fatigue for your workers means better compliance.

Features:

- LPD (low pressure drop) exhalation valve provides easier breathing
- Latex-free, stapled headstraps are strong and durable
- Adjustable contoured nosepiece plus inner foam nosepiece for better fit and comfort
- Strong, double-shell construction
- 10 per box

Applications:

- Ideal for dusty environments, i.e. grinding, sanding, sweeping, bagging, stone quarrying, metal machining, cement, underground mining, polishing, buffing, lime, poultry and textiles

Regulations:

- NIOSH Approved N95



Description	Case Qty.	Art #
Dust & Mist Respirators w/ Exhalation Valve	100	18991111

CORDED EAR PLUGS

- Patented dual material design combines firm core for easy handling with soft flanges for comfort and fit
- FlexiFirm stem is easy to grasp, ensuring easy insertion into the ear canal
- SoftFlanges creates comfortable seal in the ear canal for superior comfort and protection
- Unique detachable nylon cord system adapts to virtually any application
- Fine-tune fit for personal comfort and safety

Recommended Industries/Use

- Agricultural
- Chemical
- Construction
- Fire Protection
- Government
- Law Enforcement
- Forestry
- Manufacturing
- Medical
- Military
- Mining
- Municipal Services
- Oil and Gas
- Steel and Metals
- Transportation
- Utilities
- Welding

Hazards

- Noise

Regulations

- NIOSH 42 CFR 84



Regulations

- 29 CFR 1910.95 - OSHA Occupational Noise Exposure (US)
- ANSI S3.19-1974 - Attenuation Test Protocol (US)

Description	Art #
Large Corded Ear Plugs	1899300304

ANDROMEDA FULL-VISION GOGGLE

- Innovative two-component technology for reliable protection and maximum wearing comfort
- Large-volume; excellently suited for users who wear glasses
- Panorama field view
- First-class eye climate thanks to optimum ventilation
- Can be combined with half masks
- Highly impact-resistant polycarbonate lens
- Unique coating (outside extremely scratchproof, inside permanently resistant to fogging)
- Fast, simple lens changes
- Individually adjustable head strap
- 100% UV protection up to 400 nm
- Complies with EN 166 and EN 170



Description	Art #
ANDROMEDA Full-Vision Goggle	0899102110

PREVAIL®

- Cool cat eye design with Grey tint lens
- Lightweight and comfortable - and will fit most faces
- Meets ANSI requirements for performance standards and traffic color recognition
- 100% UV protection, impact protection
- Popular sporty design that encourages compliance
- Durable nylon frame with universal nose bridge
- Available with scratch-resistant hardcoating or optional Fog-Ban anti-fog coating

Hazards

- Abrasion
- Airborne Particulates
- Biohazard
- Impact
- Low Visibility

Regulations

- ANSI Z87+ - Meets ANSI Z87+ (High Impact) standard
- AS/NZS 1337



Description	Art #
Prevail®	08991070

HARLEY-DAVIDSON® SAFETY EYEWEAR

Silver frame with Blue Mirror Lens

- Contemporary, wrap-around sport styling with a dual lens look, molded inside shields and brow guards

Description	Art #
Harley-Davidson® Safety Eyewear	18992100



STANDARD GLASSES

- Safety eyewear for visitors
- Wide viewing area with excellent coverage
- Can be worn over most prescription eyewear (OTG compatible)
- Available with scratch-resistant hardcoating
- Made in the USA

Recommended Industries/Use

- Agricultural
- Food Services
- Forestry
- Manufacturing
- Medical
- Mining
- Municipal Services
- Pharmaceutical
- Utilities

Hazards

- Abrasion
- Airborne Particulates
- Biohazard
- Impact
- Low Visibility

Regulations

- ANSI Z87+ - Meets ANSI Z87+ (High Impact) standard
- CSA Z94.3
- AS/NZS 1337 - EC Category PPE Category II
- EN 166/EN 170
- European Directives 89/686/EEC
- Quality Assurance ISO 9001/2000
- Optical Class 1 Impact Rating F



Description	Art #
Standard Glasses	189910201

BLACK FRAME WITH CLEAR LENS

- High-tech, high style wraps around the face to provide 180 degrees of panoramic vision and excellent side and brow coverage

Description	Art #
Black Frame w/ Clear Lens	18992503



DISPOSABLE LATEX GLOVES

- Made of natural latex
- Pre-powdered with corn starch
- Translucent white
- 100 per box

Size	Art #
Medium	089946002
Large	089946003
Extra Large	089946004
Medium Non-Powdered	089947002
Large Non-Powdered	089947003
Extra Large Non-Powdered	089947004



CAUTION: Components used in making latex gloves may cause an allergic reaction in some people.

BLUE HEAVY DUTY LATEX GLOVES

- Thicker than most other heavy duty gloves
- Avg. 18 mils at the fingertip
- Designed specifically for mechanics
- Textured fingers and palms for enhanced gripping.
- Extra long cuffs
- Polymer coating makes gloves easier to put on and reuse
- Powder free
- 50 per bag

Size	Art #
Medium	089941502
Large	089941503
Extra Large	089941504



CAUTION: Components used in making latex gloves may cause an allergic reaction in some people.

BLACK NITRILE GLOVES

- WÜRTH high performance industrial grade black nitrile gloves.
- Powder free and latex free. Contain no latex proteins, and no powder that can leave residue.
- Provide superior comfort and strength, combined with unsurpassed tactile sensitivity.
- 3 times the puncture resistance of comparable latex or vinyl gloves.
- Textured for enhanced dexterity.

Size	Art #
Medium	0899470328
Large	0899470329
Extra Large	0899470330
Extra Extra Large	0899470331



NITRILE GLOVES

- 100% Nitrile gloves
- Strong and sensitive
- Powder free
- Solvent resistant
- Ambidextrous
- Blue in color
- 100 per box

Size	Art #
Medium	1899440102
Large	1899440103
Extra Large	1899440104
Extra Extra Large	1899440105



PVC GLOVES

- Recommended for oils, acids, caustics, greases, most solvents and chemicals

Size	Art #
Extra Large	0899430



NITRILE GLOVE "BASIC"

- Lightly coated nitrile glove
- 100% cotton-interlock lining with rope band
- Liquid, oil, and grease repellent



Application:

General handling, maintenance, assembling

Size	Art #
Small	089940307
Medium	089940308
Large	089940309
Extra Large	089940310



NITRILE GLOVE "WELL NIT"

- Nitrile coated gloves
- Seamless 100% nylon carrier texture



Application:

General mechanic works in industry, specialty construction industry, automotive industry, carriage factory and working, wood processing, agriculture, transportation, storage, assembly.



Size	Art #
Small	089944407
Medium	089944408
Large	089944409
Extra Large	089944410

FOAM NITRILE GLOVE "AIRFLEX"

- Grey foam nitrile palm coating on 13 gauge seamless nylon liner
- Good breathing



Application:

General handling, maintenance, assembling



Size	Art #
Small	0899400414
Medium	0899400415
Large	0899400416
Extra Large	0899400417
Extra Extra Large	0899400418

PROTECTIVE GLOVE "DY FLEX"

- Surface hand inside with PU coating
- Carrier fabric made of Dyneema®. Dyneema® is a high-strength polyethylen brin, extreme cut resistant, abrasion-resistant, flexible and comfortable to wear.



Application:

High abrasion and cut resistant. Excellent in touch and good finger-feeling.



Size	Art #
Small	0899400351
Medium	0899400352
Large	0899400353
Extra Large	0899400354
Extra Extra Large	0899400355

ASSEMBLY GLOVE "TOUCH"

- 35% cotton and 65% polyester shell
- Coated on one side with PVC dots



Application:

Light to medium mechanical tasks primarily in dry areas, can be used as dirt gloves, for light to medium warehouse work, agriculture and forestry work.

Size	Art #
Extra Large	0899404120



PROTECTIVE GLOVE "MAXCUT"

- Surface hand inside with latex coating
- Carrier fabric made of Kevlar® (made by DuPont).
Kevlar® is a high-strength paraaramid brin, extreme cut resistant, abrasion-resistant and heat resistant.



Application:

High abrasion and cut resistant. Excellent in touch and good finger-feeling.

Size	Art #
Small	089945107
Medium	089945108
Large	089945109
Extra Large	089945110
Extra Extra Large	089945111



MECHANIC GLOVE "GRIP"

- Palm made of simulated leather, 65% nylon and 35% polyurethane
- Back of the hand made of Spandex top material



Application:

General mechanic work, assembly work esp. situations which need good grip.

Size	Art #
Small	0899400548
Medium	0899400549
Large	0899400550
Extra Large	0899400551
Extra Extra Large	0899400552



MECHANIC GLOVE "HIGHEND"

- Grotech® Synthetic leather palm
- Elastic spandex superb material and neoprene on back
- Half finger in thumb and forefinger



Application:

General mechanic work, assembly work esp. situations which need to pick up small parts.

Size	Art #
Medium	0899400566
Large	0899400567
Extra Large	0899400568



MECHANIC GLOVE "SPEED FIT"

- Synthetic leather (Clarino) on the palm and Spandex /Nylon on the back



Application:

Assembly, material handling, etc.

Size	Art #
Medium	08994003
Large	08994002
Extra Large	08994001



LEATHER GLOVES

- Gun pattern leather palm gloves
- Quality gun cut, grey split leather, no exposed seams in palm "wear area"
- Wing thumb, all leather index finger and thumb, knuckle strap and elastic

Description	Art #
Leather Gloves	0899400



TOP COWHIDE GLOVES

High quality leather gloves, very soft

- Especially supple
- Good flexibility and grip
- All-leather index finger
- Sturdy work gloves made from cowhide
- Heavy cotton back and cuff
- Safety elastic on back
- Leather knuckle protection and fingertips
- Completely double-stitched, half cotton lining

Areas of application:

Medium to heavy duty mechanical work. Provides good flexibility and sure grip for activities in metal processing, bodywork, transport, woodworking, repairs, installations and maintenance. Limited suitability in wet conditions.



Description	Art #
TOP Cowhide Gloves	0899402

5 FINGER WELDER'S GLOVES

- Hand inner surface of all-cowhide leather
- Split leather back and cuff
- Universally suited for welding, deburring, general labor
- Very sturdy and durable
- Oil, grease and water repellent
- Total length 35 cm

Description	Art #
5 Finger Welder's Gloves	0984314





WURTH USA Inc.
93 Grant Street
Ramsey, NJ 07446
1-800 WURTH USA (987-8487)
www.wurthusa.com

© WURTH USA Inc. 2011
Printed in New Jersey
The information enclosed is privileged and confidential property of WURTH
USA, Inc. Any dissemination, distribution or copying of this communication is
strictly prohibited.